

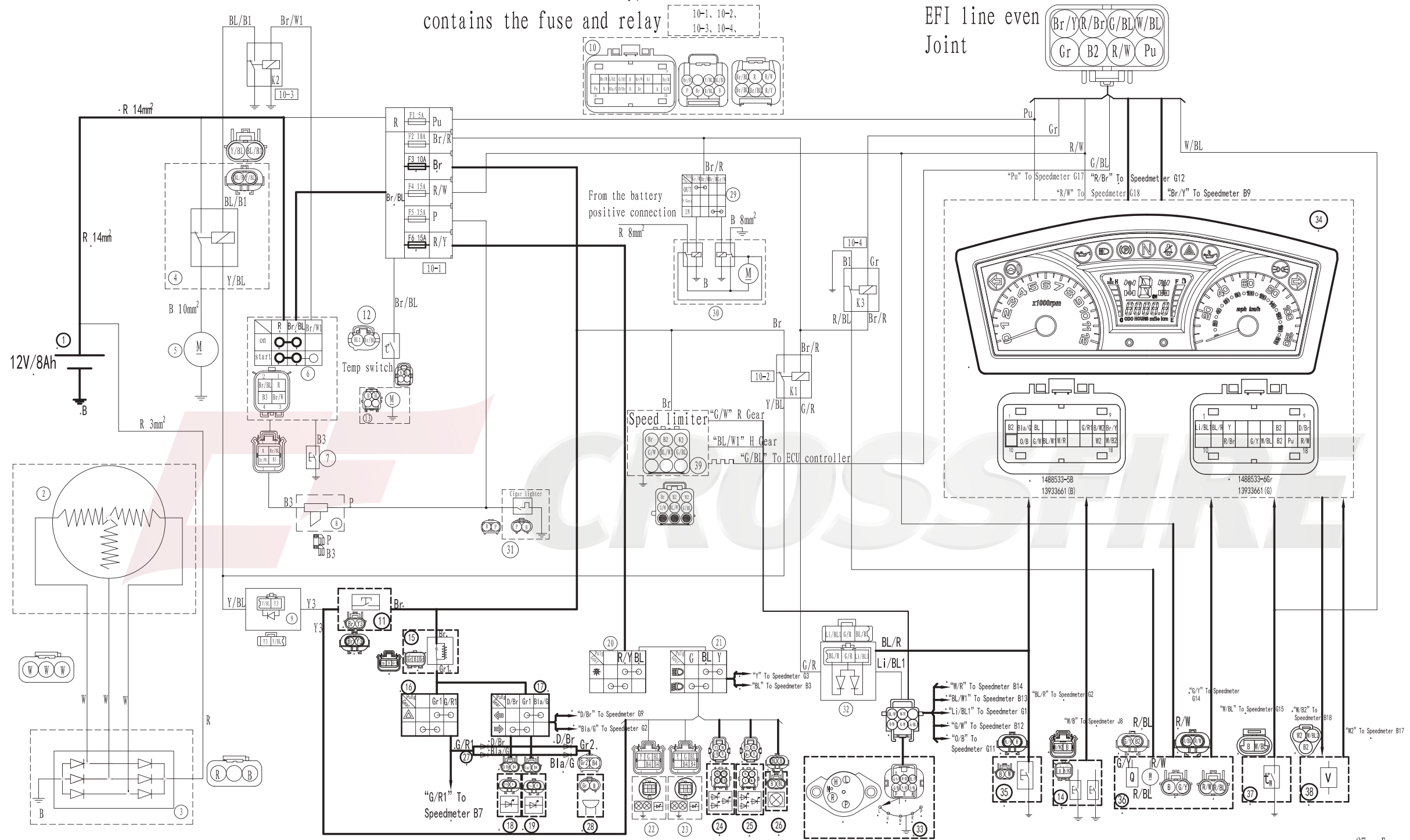

# SIGNALING SYSTEM CIRCUIT DIAGRAM

The combination of relay, contains the fuse and relay

EFI line even Joint



- |                                   |  |                                 |
|-----------------------------------|--|---------------------------------|
| 1. Battery parts                  | 24. Rear brake light assy. (L)         | 27. Emergency lamp dilde        |
| 11. Brake switch                  | 25. Rear brake light assy. (R)         | 28. Buzzer                      |
| 14. Safety belt lock catch switch | 26. Rear registration plate lamp assy. | 33. Documents show assy.        |
|                                   |  | 34. Speedmeter part             |
|                                   |  | 35. Parking final motion switch |
|                                   |  | 36. Fuel pump parts             |
|                                   |  | 37. Water temperature sensor    |
|                                   |  | 38. The speed sensor            |
|                                   |  | 39. Speed limiter               |