

Delphi Small Engine Management System Service Manual

Rev. 1.0

Preface

About Delphi Corporation

About Delphi

Delphi is a leading global supplier of mobile electronics and transportation systems, including powertrain, safety, steering, thermal, and controls & security systems, electrical/electronic architecture, and in-car entertainment technologies. Engineered to meet and exceed the rigorous standards of the automotive industry, Delphi technology is also found in computing, communications, consumer accessories, energy and medical applications.



Headquartered in Troy, Mich., Delphi has approximately 146,600 employees and operates 150 wholly owned manufacturing sites in 34 countries with sales of \$18.1 billion in 2008.

Information accurate as of December 31, 2008.

This manual is supplied as supporting material to OEM's vehicle service manual. Service personnel should contact OEM's service department for any vehicle service related questions, including Engine Management System related questions.

Table of Contents

1. Introduction

1.1. What is EMS

1.2. Typical Components of EMS

1.3. Comparison of EMS and Carburetor

1.4. Layout of EMS components

2. Components of EMS

2.1. Electronic Control Unit (MT05)

- 2.1.1. Part List
- 2.1.2. Description and Working Principle
- 2.1.3. Appearance
- 2.1.4. Dimension
- 2.1.5. Identification and Markings
- 2.1.6. ECU Connector Pin Configuration
- 2.1.7. Handling – DOs & DONTs
- 2.1.8. Installation Requirements
- 2.1.9. Power Requirements
- 2.1.10. Temperature Requirements
- 2.1.11. Maintenance, Service and Repair

2.2. Electronic Control Unit (MC21)

- 2.2.1. Part List
- 2.2.2. Description and Working Principle
- 2.2.3. Appearance
- 2.2.4. Identification and Markings
- 2.2.5. ECU Connector Pin Configuration
- 2.2.6. Handling – DOs & DONTs
- 2.2.7. Installation Requirements
- 2.2.8. Power Requirements
- 2.2.9. Temperature Requirements
- 2.2.10. Maintenance, Service and Repair

2.3. Multec 3 and Multec 3.5 Injectors

- 2.3.1. Part list
- 2.3.2. Description and Working Principle
- 2.3.3. Appearance
- 2.3.4. Seal Rings
- 2.3.5. Seal Rings Replacement
- 2.3.6. Lubricant Recommendation
- 2.3.7. Over Voltage
- 2.3.8. Temperature
- 2.3.9. Fuel Contamination
- 2.3.10. Wire Routing
- 2.3.11. Handling – DOs & DONTs
- 2.3.12. Installation guidelines
- 2.3.13. Adjustments
- 2.3.14. Interchangeability
- 2.3.15. Plugging
- 2.3.16. Cleaning Procedure

2.4. Throttle Body Assembly(with Stepper Motor)

- 2.4.1. Part list
- 2.4.2. Description and Working Principle
- 2.4.3. Appearance
- 2.4.4. Technical Parameters

- 2.4.5. Operating Conditions
- 2.4.6. Throttle Body Removal
- 2.4.7. Cleaning Procedure
- 2.4.8. Throttle Body Installation
- 2.4.9. Precautions
- 2.4.10. Handling – DOs and DONTs

2.5. Throttle Body Assembly(w/o Stepper Motor)

- 2.5.1. Part list
- 2.5.2. Description and Working Principle
- 2.5.3. Appearance
- 2.5.4. Technical Parameters
- 2.5.5. Operating Conditions
- 2.5.6. Throttle Body Removal
- 2.5.7. Cleaning Procedure
- 2.5.8. Throttle Body Installation
- 2.5.9. Precautions
- 2.5.10. Handling – DOs and DONTs

2.6. Engine Coolant Temperature Sensor

- 2.6.1. Part List
- 2.6.2. Description and Working principle
- 2.6.3. Appearance
- 2.6.4. Installation Requirement
- 2.6.5. Operating Environment
- 2.6.6. Storage Environment
- 2.6.7. Electrical Environment
- 2.6.8. Sample Cleaning

2.7. Engine Temperature Sensor (ETS)

- 2.7.1. Part List
- 2.7.2. Description and Working principle
- 2.7.3. Appearance
- 2.7.4. Installation Requirement
- 2.7.5. Electrical Environment
- 2.7.6. Sample Cleaning

2.8. Intake Air Temperature Sensor (MAT)

- 2.8.1. Part List
- 2.8.2. Description and Working principle
- 2.8.3. Appearance
- 2.8.4. Operating Environment
- 2.8.5. Storage Environment
- 2.8.6. Electrical Environment
- 2.8.7. Sample Cleaning

2.9. Intake Air Temperature and Pressure Sensor (MAT&MAP)

- 2.9.1. Part List
- 2.9.2. Description and Working principle
- 2.9.3. Appearance
- 2.9.4. Operating Environment
- 2.9.5. Storage Environment
- 2.9.6. Electrical Environment
- 2.9.7. Sample Cleaning

2.10. Oxygen Sensor

- 2.10.1. Part List
- 2.10.2. Description and Working principle
- 2.10.3. Appearance
- 2.10.4. Technical Parameters
- 2.10.5. Installation Requirements

2.10.6. Fuel Quality Requirements

2.11. Ignition Coil

2.11.1. Part List

2.11.2. Description and Working principle

2.11.3. Appearance

2.11.4. Technical Parameters

2.11.5. Installation Requirements

2.11.6. Handling – DOs and DONTs

2.12. Evaporative Canister Purge Valve (ECP)

2.12.1. Part List

2.12.2. Description and Working principle

2.12.3. Appearance

2.12.4. Technical Parameters

2.12.5. Installation Requirements

2.13. Fuel Pump Module

2.13.1. Part List

2.13.2. Description and Working principle

2.13.3. Appearance & Components of Fuel Module

2.13.4. Dimensions

2.13.5. Identification and Markings

2.13.6. Operating Conditions

2.13.7. Service Parts

2.13.8. Service Procedure

2.13.9. Handling – DOs and DONTs

3. Diagnostic Tools

3.1. Motor Scanner(for MT05 EMS)

3.1.1. Precautions

3.1.2. Configurations

3.1.3. Preparations

3.1.4. Functions

3.2. Diag Tool Software(for MC21 EMS)

3.2.1. General Description

3.2.2. Diagnostic Connector Pin Definition

3.2.3. Diag Tool Software Instruction

3.3. PCHUD Software(for MT05 EMS)

3.3.1. General Description

3.3.2. Diagnostic Connector Pin Definition

3.3.3. PCHUD Software Instruction

Document Revision Record

Rev. #	Revision Content	Written by	Approved	Date
1.0	Original copy	Evan Yang	Lei Shi	April, 2009

1. Introduction

1.1. What is EMS?

An **EMS (Engine Management System)** is a self contained set of components including a custom built computer and sensors and actuators which control the operation of an engine by monitoring the engine speed, load and temperature and providing the ignition spark at the right time for the prevailing conditions and metering the fuel to the engine in the exact quantity required.

In simplest terms, the purpose of fuel injection is to deliver fuel to achieve the desired air/fuel mass ratio to the engine. Fuel atomization and injector targeting play critical roles in achieving this ratio. The accuracy of the air/fuel mass ratio has a direct effect on emissions, fuel economy, power and drivability, start quality and idle quality.

1.2. Typical Components of EMS

Typically EMS for small gasoline engine consists of the following components

- Crank position sensor (Supplied by vehicle manufacturer)
- Engine control unit (Delphi Part, refer part list for part no)
- Engine temperature sensor (Delphi part)
- Fuel injector (Delphi part, Refer part list for part no)
- Fuel module – Pump, pressure regulator and strainer (Delphi part)
- Intake air temperature sensor (Delphi part)
- Intake pressure sensor or MAP/MAP sensor (Delphi part)
- Throttle body assembly – Throttle body, Idle air adjust screw or valve, Throttle Position sensor, (Delphi part)
- Inductive Ignition coil (Delphi part)
- Oxygen sensor(Delphi part)
- Evaporative Canister Purge Valve

1.3. Comparison of EMS and Carburetor

- Better Air and Fuel Control – Resulting in better pick up and faster response
- Lower mechanical complexity – Unlike carburetor the EMS bike does not have choke or any other mechanical levers, this reduces the mechanical complexity and gives more flexibility to the driver

- Easy to service – The serviceability of the EMS is easy. By the use of its powerful diagnostic tool system malfunctions can be easily detected and corrected. Faultfinding and error proofing by using advanced diagnostics.
- Better cold startability – The driver need not worry when he/she is starting the bike early morning. The powerful on board computer measures the temperature of the ambient conditions and the engine conditions and provides necessary fuel that the bike starts instantly
- Lower emissions
- Better Drivability – Due to better control and response the drivability of the vehicle is considerably enhanced giving driving pleasure the utmost priority. EMS takes biking to the next level in ensuring that the driver enjoys the ride very comfortably.
- Better hot fuel handling
- Better altitude compensation
- Fuel Timing control
- Improve fuel economy (engine dependent)
- Better take off

1.4. Layout of EMS Components

Figure 1 below shows the layout of typical EMS for a two cylinder engine. The actual layout may slightly differ based on the application and users are advised to contact the vehicle manufacturer for the actual layout. The solid lines in the figure 1 below indicate the output signals from the Engine Controller and the dotted lines indicate the input signals to the controller from various sensors and switches.

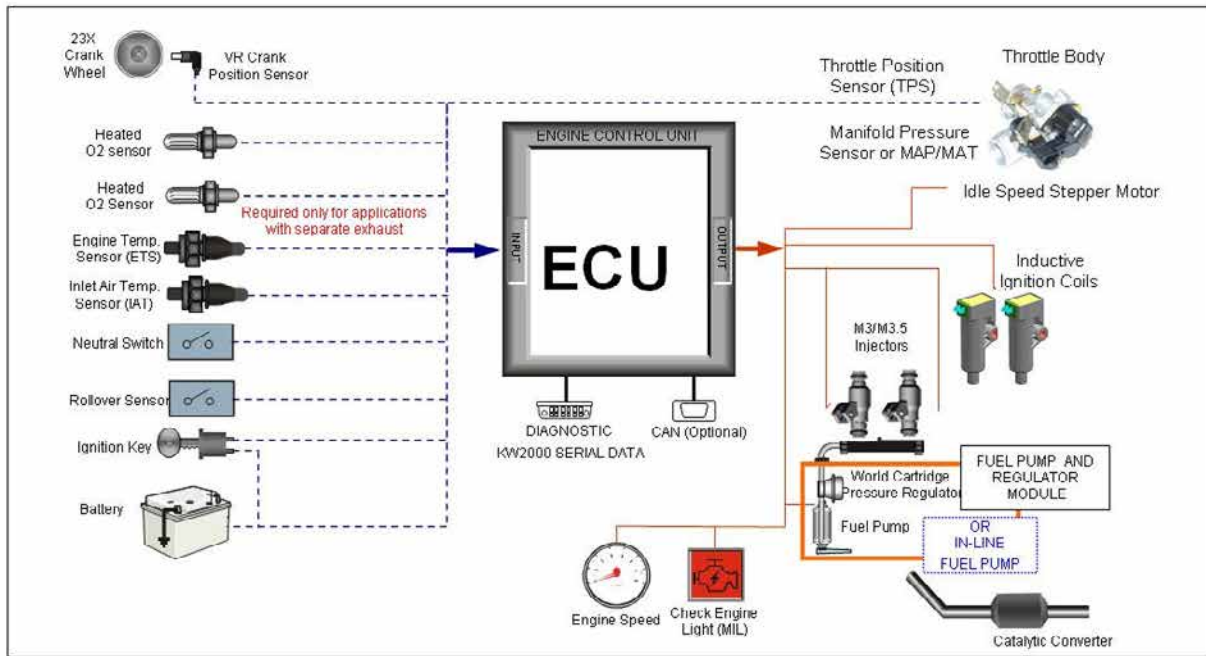

Figure 1

Legend:

- Dotted line indicates inputs
- Solid line indicates outputs

2. Components of EMS

2.1. Electronic Control Unit (MT05)

2.1.1. Part List

MT05 ECU Part List		Table: 1
Part Name	Remarks	
MT05 Generic 1 CYL ECU	36 pins	
MT05 Generic 2 CYL ECU	36 pins	
MT05 2 CYL ECU w 2 O2 Sensors	36 pins	
MT05.1 Generic Low Cost 1 CYL ECU	18 pins only	
MT05 1 CYL ECU WO IACV	36 pins	

2.1.2. Description & Working Principle

The ECU continuously monitors the operating conditions of the engine through the system sensors. It also provides the necessary computation, adaptability, and output control in order to minimize the tailpipe emissions and fuel consumption, while optimizing vehicle drivability for all operating conditions. The ECU also provides diagnosis when system malfunctions occur.

2.1.3. Appearance

The MT05 ECU has a polyester header, with an aluminum base plate. Figure 2 below shows the top and bottom view of the MT05 ECU.



Figure 2

2.1.4. Dimensions

The maximum physical envelope of the ECU is 103 x 92.6 x 27.1 mm. These dimensions include the mounting feature on the ECU, but do not include the assembled connector harness and pipe joint. Refer to Figure 3 below for the dimensions of the ECU with the mounting features included.

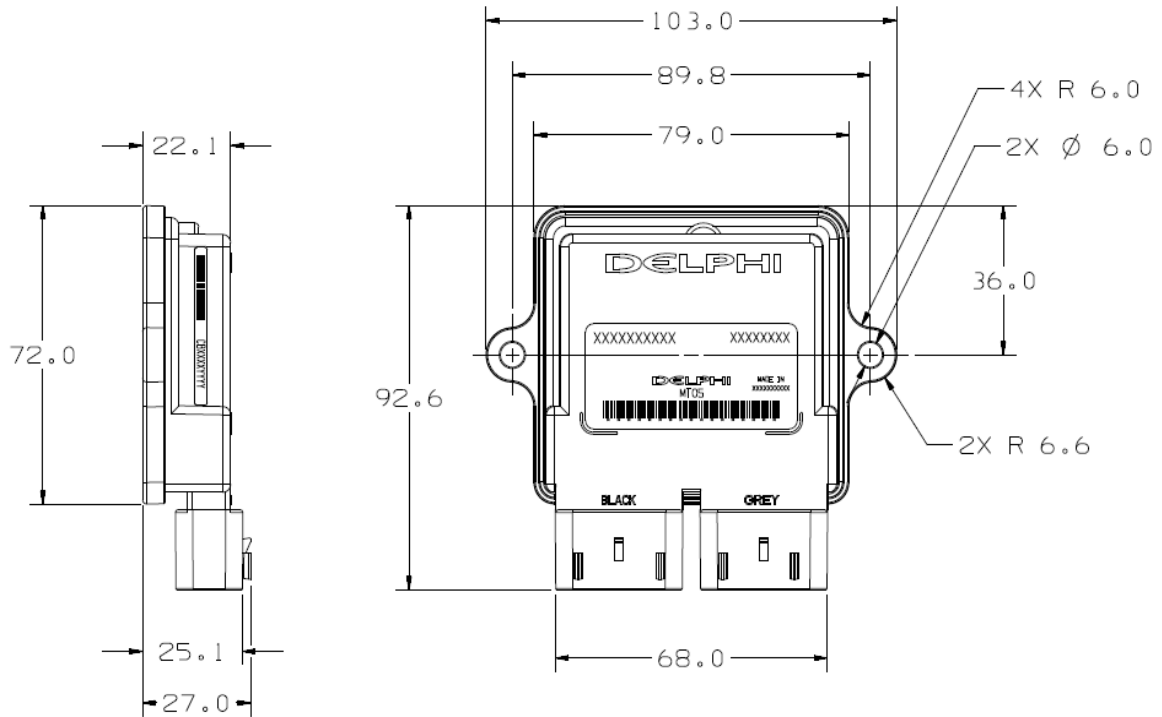

Figure 3

2.1.5. Identification and Markings

Each ECU is identified with a product label for traceability that includes the Delphi and Customer Part number, Customer Vehicle Platform Number, ECU Model Description and Manufacture Date. These details should not be defaced or soiled when the ECU is returned to the vehicle manufacturer for investigation. If these details are not available or defaced, Delphi shall not be hold responsible for the ECU investigation and replacement. Refer to Figure 4 below for more details.

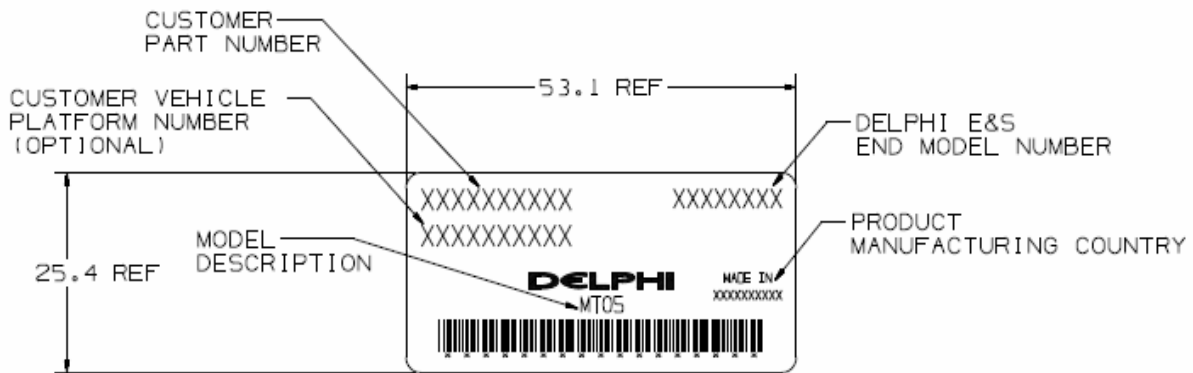
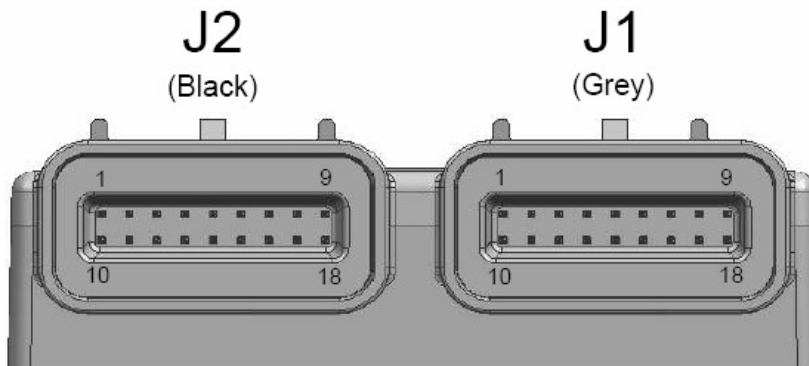

Figure 4

2.1.6. ECU Connector Pin Configuration

Figure 5A below shows the pin configuration of these two connectors on the **ECU**. Figure 5B below shows a typical wiring diagram for twin cylinder engine. Please contact vehicle manufacture for the actual wiring diagram due to it is based on specific application.



CONNECTOR J1		CONNECTOR J2	
PIN #	Description	PIN #	Description
1	IACAH/IAV	1	COILA/ESTA
2	MAGNETO CUT RELAY/CLTL/ESTC	2	GND (Power)
3	MIL	3	KW2000
4	DEAD BATT BYPASS/O2B HTR/INJC	4	Crank VR Hi (23XHIF1)
5	SPARE ANALOG/NGK	5	INJA
6	TACHOMETER	6	INJB
7	CANLO	7	O2A HTR
8	CANHI	8	IAT_MAT
9	GND (Power)	9	FUEL PUMP RELAY
10	COILB/ESTB	10	5VRTN
11	IACALO	11	MAP
12	IACBHI	12	TPS
13	IACBLO	13	Crank VR Lo (23XLOF1)
14	ROLLOVER	14	CLT
15	VSS/O2B Sensor	15	IGN
16	DIAG	16	5VREF
17	Fuel Pump Re-Cir	17	O2A Sensor
18	PNSW	18	VBATT

Note: For MT05.1, only J2 will be populated and in this instance, KW2000, DIAG and MIL will share one pin as indicated in the PMD.

Figure 5A

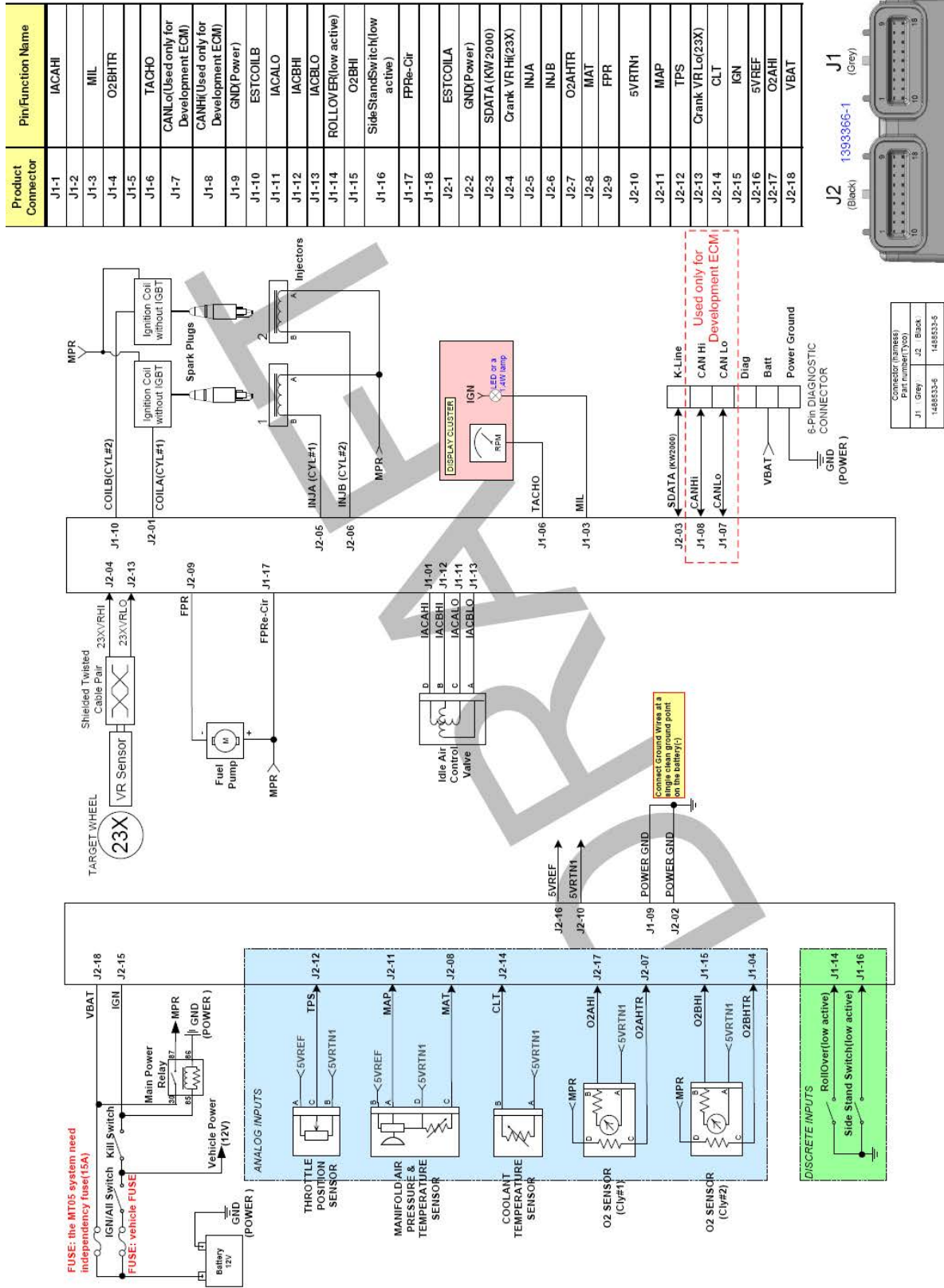

Figure 5B

2.1.7. Handling – DOs & DONTs

MT05 ECU Handling		Table: 2
ACTION	REASON	
DO NOT: Place the ECU close to the exhaust pipe or Engine when removed	High temperature might reduce the life of the ECU and also can damage the ECU	
DO NOT: Place the ECU close to or pour water, oil or any other liquids.	ECU is susceptible to water and liquids	
DO NOT: Allow mud or other debris to accumulate on the surface of the ECU	Having mud or debris accumulated on the ECU casing reduces its heat dissipation efficiency.	
DO NOT: Apply any voltage relative to any point to the ECU	Drastically affects the performance of the ECU and may lead to ECU damage	
DO NOT: Clean ECU with any solvent or any corrosive liquid	Can damage the housing of the ECU	
DO: Take extreme care that water droplets or excess moisture should not fall on ECU connectors	ECU connectors can get short and may lead to ECU damage	
DO: Clean the ECU with a moist cloth and keep it dry	Prevents ECU damage	

2.1.8. Installation requirements

The ECU shall be mounted using M5 machined screws with a torque of 3.9Nm \pm 10%. The mounting surface should also be flat to avoid subjecting the base plate to unnecessary force and warping the PCB.

2.1.9. Power Requirements

- **Power Supply:** The controller's power supply module will power up the microprocessor if the battery voltage is greater than 6.3 Volts. The power on is controlled by the controller hardware only.
- **Operating Range:** All planned functions are executed in this range. Battery and/or Ignition voltage: 9.0 to 16V DC
- **Power Off:** The controller will turn its power off when the ignition voltage: < 6.2 V DC. The controller prepares for entry into Power Down mode. The preparation involves storing important information into EEPROM.
- **Reset:** During reset, all outputs shall be set to a predefined state. The controller shall monitor itself for proper operation and enter reset should any internal errors be detected. The controller shall then restart normal operations after the computer has properly reset
- **Over Voltage:** the controller will survive no permanent damage if the ignition voltage do not exceed 26V for more than 1 minute
- **Reverse Voltage:** The controller will survive with no permanent damage: Battery and/or Ignition voltage < -13V DC for 1 minute

2.1.10. Temperature Requirements

- Storage: The controller shall suffer no damage as a result of being stored at temperatures of -40 °C or +105 °C continuously for 168 hours. If the storage temperature is not as extremely high as +105 °C or as extremely low as -40 °C, the ECU could be stored for longer time without damage.
- Operating: The controller shall operate in the ambient temperature from -20 °C to +85 °C.

2.1.11. Maintenance service and Repair

ECU is a non-serviceable part. Once there are problems, it's important to first determine if the problem is caused by software/calibration. If it is caused by software/calibration, please refer to software/calibration reflashing procedure. In the event of ECU hardware failure or malfunction (during warranty period only) the ECU should be sent back to the vehicle manufacturer giving complete details of the ECU Part No, Serial number, Vehicle Model & Make, manufacturing Date, Total kms run on the vehicle, Location of use, Vehicle No, Date of return.

Refer to the form 1 shown below. The form should be completely filled by the dealer and the original form and the ECU should be sent to the vehicle manufacturer for further investigation. These actions should be taken only during the warranty period. Else ECU has to be replaced by the dealer at the vehicle owner's cost.

Form 1

DELPHI	ECU Failure Initiation Form	<i>××× motor company</i>
Dealer Name:	Vehicle Make and Model Name:	Incident Date:
Address:	Engine Size:	
	MFD for the Vehicle:	
	Kilometers Run during the Incident:	
	Description of the Part:	
Contact No:	Part No of the ECU:	
Mobile phone:	Serial No of the ECU:	
Contact person:	Manufacturer date of the ECU:	
Description of the incident when the failure took place:		
Condition of the part when the incident occurred / when examined:		
Actions taken by the vehicle owner and the dealer on the part and the vehicle during and after the incident:		
Additional Observations about the suspected part and vehicle condition:		

This is the exclusive property of Delphi Corporation. Without their consent, it may not be reproduced or given to third parties.

2.2. Electronic Control Unit (MC21)

2.2.1. Part List

MC21 ECU Part List		Table: 3
Part Name	Remarks	
MC21 1020	Single cylinder	
MC21 1050	Twin cylinder	

2.2.2. Description & Working Principle

MC21 is the older generation 16-bits control unit on limited small engine applications. ECU monitors the data includes engine temperature, intake air pressure, crank angle, oxygen in exhaust gas etc, and deliver the accurate fuel with spark timing to achieve best fuel economy and engine performance.

2.2.3. Appearance

MC21 housing uses plastic and glass fiber with potting glue to achieve various shock protection and waterproof. The drawing of appearance is figure 6 as below.
ECU Size

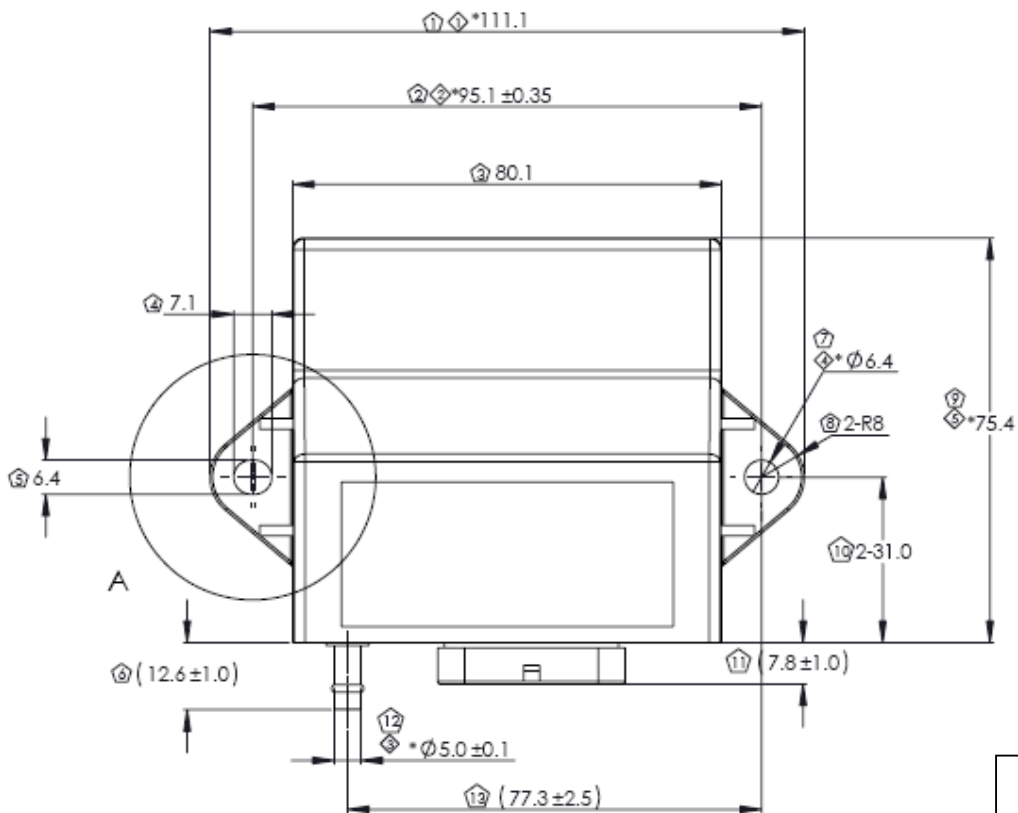

Figure 6

2.2.4. Identification and Markings

ECU has label for traceability as figure 7 below. The information includes ECU type, part number, customer number, hardware number, manufacture number, software version and bar-code. If the label information is erased or soiled, it will affect warranty.



Figure 7

2.2.5. ECU Connector Pin Configuration

The drawing below is the 34pins connector configuration. Please make sure I/O loading is as the list specs. They are shown in figure 8 and figure 9.

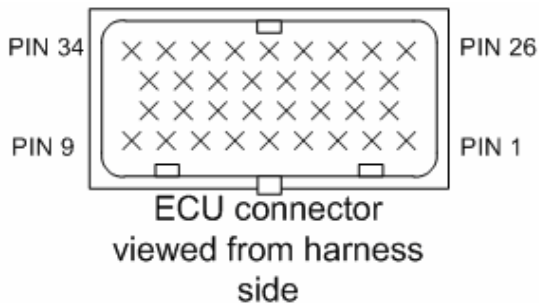
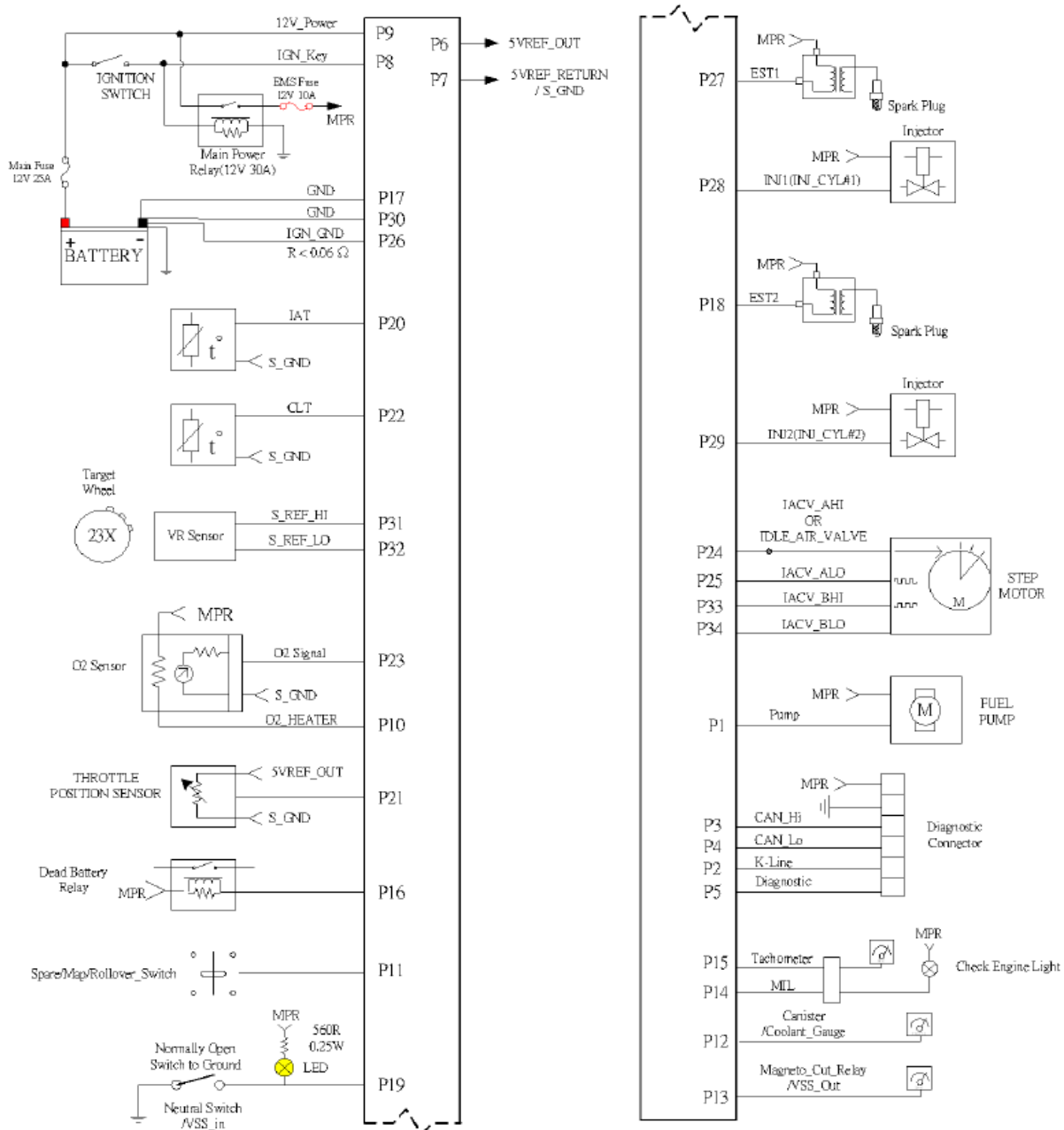

Figure 8

Pin Number	Pin def	Operation Voltage			Operation Current(A) at Voltage(V)	
		Min	Normal	Max	Max	
		V	V	V	mA	V
1	PUMP	6.5	14.5	16	4000	16
2	K-LINE	6.5	14.5	16	140	16
3	CAN_Hi	0	0~4.5	4.5	100	4.5
4	CAN_Lo	0	0~2.25	2.25	100	2.25
5	Diagnostic	0	NA	16	5	16
6	5VREF_OUT	4.81	5	5.19	50	5.19
7	5VREF_RETURN / S_GND	NA	NA	NA	NA	NA
8	IGN_KEY	6.5	14.5	16	1000	16
9	12V Power	6.5	14.5	16	6000	16
10	O2_HEATER	6.5	14.5	16	2000	16
11	Spare / Map /Rollover_Switch	0	NA	16	5	16
12	Canister / Coolant_Gauge	6.5	14.5	16	1000	16
13	Magneto_Cut_Relay / VSS_Out	6.5	14.5	16	1000	16
14	MIL	6.5	14.5	16	1000	16
15	Tachometer	6.5	14.5	16	1000	16
16	Dead_Battery_Relay	6.5	14.5	16	1000	16
17	GND	NA	NA	NA	NA	NA
18	EST2	6.5	14.5	16	13000	16
19	Natural_Switch / VSS_in	0	NA	16	5	16
20	IAT	0	5	5.19	5	5.19
21	TPS	0	5	5.19	5	5.19
22	CLT	0	5	5.19	5	5.19
23	O2 Signal	0	5	5.19	10	5.19
24	IACV_AHI / IDLE_AIR_VALVE	6.5	14.5	16	400 / 2000	16
25	IACV_ALO	6.5	14.5	16	400	16
26	IGN_GND	NA	NA	NA	NA	NA
27	EST1	6.5	14.5	16	13000	16
28	INJ1	6.5	14.5	16	2000	16
29	INJ2	6.5	14.5	16	2000	16
30	GND	NA	NA	NA	NA	NA
31	S_REF_Hi	0.6	10	80	100	80
32	S_REF_Lo	0.6	10	80	100	80
33	IACV_BHI	6.5	14.5	16	400	16
34	IACV_BLO	6.5	14.5	16	400	16

Figure 9

The figure 10 as below is the mech drawing of MC21 1050, please make sure the power and ground line are as the reference design.



BLOCK DIAGRAM

Figure 10

2.2.6. Handling – DOs & DONTs

MC21 ECU Handling		Table: 4
Item	Reason	
Do not: Place ECU close to engine and exhaust pipe when remove.	ECU life maybe susceptible to high temperature. And high temperature may damage the plastic covering.	
Do not: Place ECU close to water, oil, liquid.	ECU maybe susceptible to liquid	
Do not: ECU to be covered by mud and stagnant water.	Block ECU surface may affect heat dissipation.	
Do not: Apply any voltage relative to point to ECU.	Drastically affects the performance of ECU and may lead to ECU damaged.	
Do not: Apply water droplet or excess moisture on connector.	ECU connector gets short or may lead to ECU damaged.	
Do not: Clean ECU with solvent or corrosive liquid.	This will damage ECU housing.	
Do: Clean ECU with moist cloth and keep it dry.	Prevent ECU damaged.	
Do: When re-installation, check the MAP nipple for any obstruction and clean it .	Prevent performance deterioration of the vehicle.	
Do: When re-installation ECU, fix the MAP pipe tighten without leakage. Make sure clip, MAP pipe and specs are provided by vehicle manufacture for the same type.	Prevent performance deterioration of the vehicle.	
Do: Always connect the MAP pipe from the ECU to the intake manifold	Prevent the dust to enter the engine and safety the vehicle.	
Do: Release the clip in MAP nipple when take off MAP pipe from ECU. And careful cannot make an effort to force the MAP pipe to be separated from ECU.	Prevent the L-type inside ECU loosed or waterproof glue broken	

2.2.7. Installation Requirements

The installation requirement of MC21 is shown in the figure 11 as below. (mounting bolt (M6) should be applied to 5Nm)

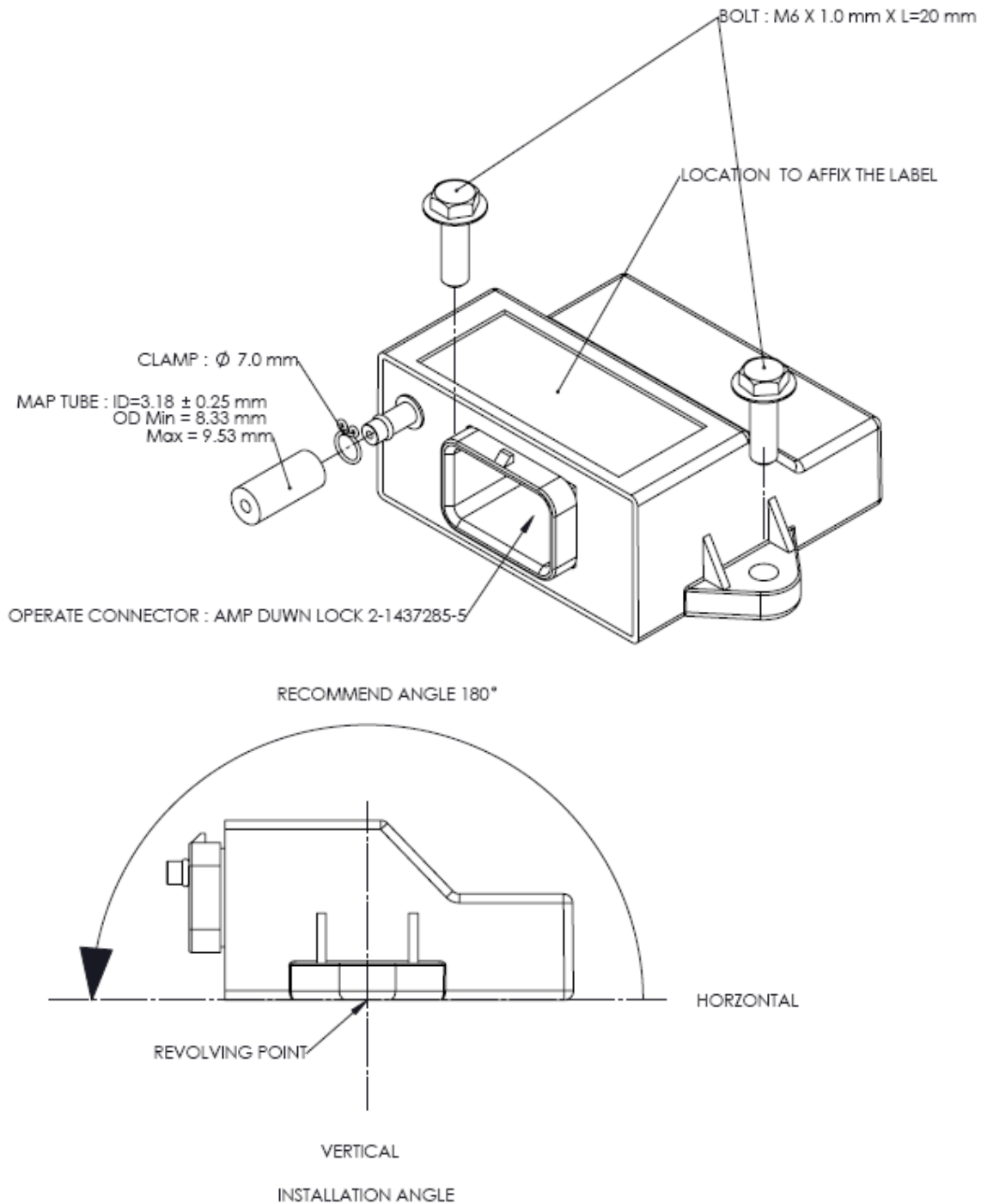

Figure 11

2.2.8. Power Requirements

- **Power on:**
In normal situation, battery input should be steady state. When IGN-KEY is on and battery voltage over 6.5V, ECU will enter normal operation.

- Operation:
Under EMS loading, battery voltage must keep in 9~16V for system operating normally.
- Power off:
When IGN-KEY off, ignition voltage is under 6.2V, ECU will start to process power down. ECU memorizes learning information in EEPROM. Such as malf-code, freeze frame, closed loop learning value, air flow correction value and TPS learning value etc. The learning value can be used for more accurate calculation in next key cycle.
- Reset mode:
When ECU request reset command or has serious problem, system should enter reset mode. All I/O port should be set the predefined state and then restart normal operations after properly reset.
- Over voltage / reverse voltage:
ECU will survive 24V over voltage for 1 minute and with no permanent damage.
ECU will survive 14V inverse voltage for 1 minute and with no permanent damage.

2.2.9. Temperature Requirements

- Normal Operating Temperature Range: - 30 to 70°C
- Max operation temperature: 80 ° C (can not over it for 30 minutes continuously)
- Storage Temperature Range: -40 to 85°C

2.2.10. Maintenance service and Repair

ECU is a non-serviceable part. Once there are problems, it's important to first determine if the problem is caused by software/calibration. If it is caused by software/calibration, please refer to software/calibration reflashing procedure. In the event of ECU hardware failure or malfunction (during warranty period only) the ECU should be sent back to the vehicle manufacturer giving complete details of the ECU Part No, Serial number, Vehicle Model & Make, manufacturing Date, Total kms run on the vehicle, Location of use, Vehicle No, Date of return.

Refer to the form 1 was shown above. The form should be completely filled by the dealer and the original form and the ECU should be sent to the vehicle manufacturer for further investigation. These actions should be taken only during the warranty period. Else ECU has to be replaced by the dealer at the vehicle owner's cost.

2.3. Multec 3 and Multec 3.5 Injectors

2.3.1. Part List

Injector Part List		Table: 5
Part Name	Remarks	
Multec 3 Injector		
Multec 3.5 Injector		

2.3.2. Description and Working Principle

The Multec 3 injector was developed to provide high levels of performance and durability to meet increasingly stringent emissions-control legislation. The Multec 3 Fuel Injector is an electromechanical device. A magnetic field is generated as voltage is applied to the solenoid coil. The resulting magnetic force lifts the core assembly, overcoming manifold vacuum, spring force, and fuel pressure, allowing fuel to pass through the ball and seat interface to the director. As the fuel passes through the director, an atomized spray is developed. The injector closes when the voltage is removed, cutting off the fuel flow.

The working principle of the Multec 3.5 injector is more or less the same with the Multec 3 injector. The difference is that the Multec 3.5 injector has better durability and response than the Multec 3 injector due to its high efficiency solenoid.

2.3.3. Appearance

The figure 12 shows the standard Multec 3 Fuel Injector appearance.

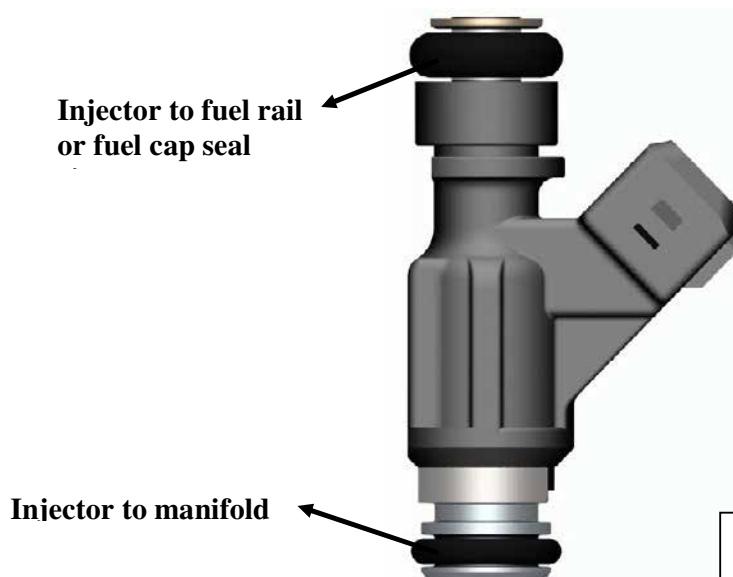
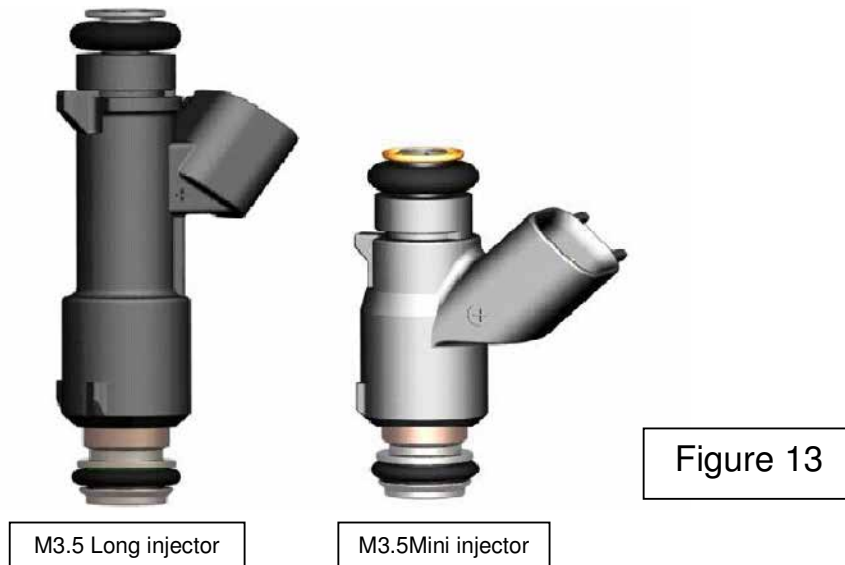

Figure 12

The standard Multec 3.5 injector has a different appearance with Multec 3 injector. The "mini" Multec 3.5 version was developed to provide fuel system packaging advantages. They are shown in figure 13 as below.



2.3.4. Seal rings

Seal rings for injectors (refer to Figure 12) are made to withstand temperatures ranging from -40°C to 150°C (-40 to 302°F) without leakage or seeping. They must also be resistant to varying amounts of fuel additives to fuel (i.e., ethanol, etc.). The following are currently available seal rings designs. Please contact a Delphi representative if the specific sealing requirements are not met by these designs:

Injector to fuel rail seal ring

- Dimensions:
 - ID. : 6.35 mm
 - OD. : 14.85 mm
 - Cross-section: 4.25 mm
- Materials
 - Viton GLT (blue color). For low temperature applications
 - Viton A (black). All other applications.

Injector to manifold

- Dimensions:
 - ID: 9.61 mm
 - OD: 14.49 mm
 - Cross-section: 2.44 mm
- Materials:
 - Viton A (black or brown other applications.)

2.3.5. Seal rings replacement

- Lubricate the seal rings with an approved lubricant or equivalent. The lubricant application process must prevent lubricant from contacting the director plate, which could possibly restrict the injector flow.
- It is preferred to not reuse the seal rings when re-installing an injector. If re-use is necessary, carefully inspect each seal ring for any signs of damage, as even minor defects can lead to fuel / vacuum leakage. Always install injectors and seal rings using the recommended service procedures to avoid the possibility of a safety hazard.
- When installing seal rings to the injector inlet, take extra care not to damage the seal on the injector top flange.

2.3.6. Lubricant Recommendation

Lubrication should be applied to the O-rings only for ease of injector installation. The table 4 is a list of lubricant oils that were tested and approved for O-ring lubrication. These lubricants have shown to have no effect on injector performance (plugging, sticking).

Lubrication Recommendation		Table: 6
Lubricant Name	Supplier	Viscosity (cSt) @ 40 °C
Spindura 10	Equilon	10
Spindura 22	Equilon	21
DTE-24	Mobil	32
DTE-25	Mobil	46
DTE-26	Mobil	68
Norpar 15	Exxon / Mobil	<1
Drawsol 60	DA Stewart	1-2
NocoLube AW 46	NOCO Energy	46
NocoLube AW 32	NOCO Energy	32
Advantage Spindle Oil	Advantage Lubrication Specialties	10

2.3.7. Over-Voltage

The Multec 3 injectors and the Multec 3.5 injectors can withstand a voltage of 26v for a maximum of one minute at a duty cycle of 100 ms pulse width and 200 ms period. The injector will be pressurized with calibration test fluid at normal operating pressure during the test. This will not result in any permanent physical damage to the injector or coil assembly, or any degradation in electrical performance.

2.3.8. Temperature Requirements:

Typical injector temperature environments are defined below. The Multec 3 injectors and the Multec 3.5 injectors will not experience any loss of the ability to comply with the flow tolerance requirements after exposure to the following temperature environments. Also, they will not experience unacceptable external leakage, any type of physical degradation, or loss of service life during or after being exposed to these ambient conditions.

- Normal Operating Temperature Range: - 30 to 125°C
- Extreme Operating Temperature Range (some performance degradation): - 40 to 150°C
- Storage Temperature Range: -60 to 60°C

2.3.9. Fuel Contamination

The injector fuel inlet filter protects the fuel injector from initial build fuel contamination as well as from fuel system assembly contamination. Filtration is extremely important because particle contaminants can cause an injector to stick open, flow shift or tip leak.

The injector inlet filter is not a serviceable component and is designed only to trap potential built-in contamination between the chassis fuel filter and injector.

2.3.10. Wire Routing

- Electrical wiring to the injector should be routed so that conductors are protected from excessive heat, damage, and wear.
- Avoid unnecessary handling (disconnecting and connecting) of the electrical connector.

2.3.11. Handling - DOs & DONTs

MULTEC 3 and 3.5 FUEL INJECTOR HANDLING		Table: 7
ACTION	REASON	
DO NOT: Re-use injector seal rings if at all possible. If no other choice exists, take extra care in inspecting the seal rings for damage.	Leakage.	
DO NOT: Dip injector tips into lubricants.	Can plug injector spray orifices.	
DO NOT: Cycle injector repeatedly without fuel pressure.	Damage to internal mechanical components.	
DO NOT: Pulse (actuate) a suspected high leak rate injector (leak >50 sccm air).	Can dislodge internal contamination if present and preclude root cause analysis.	
DO NOT: Allow water to enter fuel system from air lines, etc. during leak checks.	Can damage injectors.	

DO NOT: Contact or apply load to the injector tip for installation.	Apply load to 45 deg angle on nylon over mold see
DO NOT: Pound injectors into manifold during assembly to engine.	Can damage injectors or seal rings.
DO NOT: Apply excessive side loads to electrical connectors.	May cause loss of electrical continuity.
DO NOT: Use any dropped unit.	Internal damage may have occurred.
DO NOT: Store injectors, rails, or subassemblies including engines on which the injectors have been installed in an unprotected environment.	External contamination can damage the injector electrically and/or mechanically.
DO NOT: Use the injector as a handle.	Do not use the injector to lift assemblies
DO NOT: Rack, stage, or handle parts in a manner that allows contact between parts.	Damage will occur.
DO NOT: Remove packing in a way that allows contact between parts.	Damage could occur due ton contact between parts.
DO NOT: Tap on fuel injectors to correct any malfunction.	Can damage injector.
DO NOT: Replace the injector with other part number not recommended for this application	Will severely affect the performance of the injector
DO: Take extra care when installing new fuel seal ring over injector inlet flange.	Prevent tearing seal ring during installation.
DO: Use proper lubricants on seal ring surfaces to install injector in engine. Minimize time between applying lubricant and inserting injector / rail.	Avoid damage to seal ring during installation. Avoid contamination at seal.
DO: Pulse (actuate) stuck closed or tip-leak suspected injector (Actuate consists of one pulse <5 sec duration at 9 to 15V).	To verify the injector failure
DO: Pulse (actuate) injectors prior to a dry fuel system leak test at engine/vehicle assembly to reseal injector valves.	Injector valves may not reseal without fuel after shipping and handling resulting in false leakage.
DO: Avoid any liquid contamination in the injector area.	Coil could short circuit.
DO: Use care during connection of harness to injector.	Avoid terminal damage.
DO: Use recommended terminal lubricant on mating connector.	Minimize potential for terminal fretting corrosion.
DO: Return any dropped, damaged, or suspect material with a tag that describes the problem.	Ensure fast and correct diagnosis of root cause.

2.3.12. Installation guidelines

Follow these guidelines to prevent damage to the injector and its electrical interface during the replacement or re-installation process.

- Lubrication: Apply a light coating of lubricant to the lower injector seal ring. ISO 10 light mineral oil or equivalent is recommended.

- The preferred technique is to apply the lubricant to the sockets the injectors are being installed into, rather than directly to the seal ring itself. This will help minimize the possibility of injector contamination.
- Avoid applying lubricant over the director plate holes – this may restrict injector flow. Do not dip the injector tip in lubricant.
- All Multec 3 and Multec 3.5 injectors come from the factory with the seal rings attached. The re-use of seal rings is not preferred when replacing an injector. If an injector is to be re-used, and no new seal rings are available, take care to inspect each seal ring for signs of damage. Even minor defects in the seal ring can lead to leakage. Take extra care in installing seal ring over flange of injector inlet.
- Carefully installing the harness connector will prevent terminal damage. Listen for a positive audible click from the connector retention device — this ensures that it is fully engaged.
- Avoid unnecessarily disconnecting/reconnecting the harness connector.
- Wires routed in a manner that can allow them to become pinched between components can result in a short circuit and a stuck open injector.
- For injectors that require orientation for spray pattern, do not rotate the injector in the fuel rail assembly to install the injector electrical connector. This may dislodge the retaining clip, and result in improper spray orientation

2.3.13. Replacement Techniques

The following procedure outlines standard Multec 3 and Multec 3.5 Fuel Injectors removal and replacement.

Warning: The injector and all associated hardware may be extremely hot.

- Shut off ignition.
- Disconnect negative battery cable to avoid possible fuel discharge if an accidental attempt is made to start the engine.
- Disconnect the electrical connector from the injector wiring harness.
- Relieve fuel pressure
- Remove the retaining clip from the fuel injector.
- Remove the fuel line connection from the injector
- Carefully clean debris from the interface surfaces. Do not damage seal mating surfaces.
- Remove the injector from the manifold
- Apply a light coating of a lubricant to both the upper and lower injector seal ring of the replacement injector.
- Install the new injector into the manifold. Check that the injector is installed in the original orientation to maintain proper spray targeting, and that the retaining clip is properly seated on the injector and the fuel line
- Install the retaining clip after connecting the fuel line

- Tighten the injector mounting to the desired torque as mentioned in the manufacturer manual
- Tighten the fuel line
- Re-install the injector electrical connector
- Check for fuel leaks with the key “on” and the engine “off”
- Start engine and verify proper operation.

2.3.14. Interchangeability

The injector should be replaced in service only with an equivalent injector of the same part number. On occasion, a new part number may supersede part numbers. Consult the appropriate vehicle service manual and part number guide for the latest replacement injector part number information.

2.3.15. Plugging

Fuel deposits cause plugging resulting in flow shifts over the life of the injector. Fuel varnish or gumming, a type of injector deposit, is created when certain types of fuel are heated by high injector tip temperatures at soak (no fuel flow). Deposit build up in the injector holes causes the flow shifts

- Plugging can cause flow restrictions, frictional changes and the collection of other particles attracted by the tacky surface. The flow restrictions can degrade emissions and drivability.
- Other fuel and environmental conditions may cause crystal or corrosion growth in the injector and cause a flow shift.
- Oxidation stability of the gasoline affects the potential for deposit formation and must be controlled by the fuel supplier.
- Increased levels of detergent additives reduce the rate of injector plugging.
- In case of plugging of injector follow the injector cleaning procedure mentioned in the section below

2.3.16. Cleaning Procedure

- Electrically disable the fuel pump by removing the fuel pump connection.
- Relieve the fuel pressure in the system and disconnect the fuel connection at the injector. Plug the fuel feed line.
- Injector cleaner with the specific ratio of the cleaner and gasoline to be mixed in the injector cleaning tank.
- Connect the injector-cleaning tank to injector in the vehicle.
- Pressurize the injector-cleaning tank to system pressure.
- Start and idle the engine for 15- 20 minutes.
- Disconnect the injector-cleaning tank from the system and install the fuel pump connections. Connect the fuel feed line to injector.

- Start and idle the vehicle for an additional 2 minutes to ensure the residual injector cleaner is flushed from system.

2.4. Throttle Body Assembly(with stepper motor)

2.4.1. Part List

Throttle Body Assembly Part List		Table: 8
Part Name	Remarks	
Throttle Body		
Throttle Position Sensor		
Idle Air Control Valve		

2.4.2. Description and Working Principle

The Throttle Body Assembly is an interactive system comprised of the following subsystems: the main casting body, bearing system, shaft and valve system, return spring system, cable interface system, throttle position sensing system, and the bypass air control system. The subsystems interact and support each other to provide all the functional requirements, which are mentioned below -

- Control intake air flow
- Control idle air flow
- Sense throttle position - Provide position feedback to Engine Controller
- Provide reactionary force to the throttle

2.4.3. Appearance

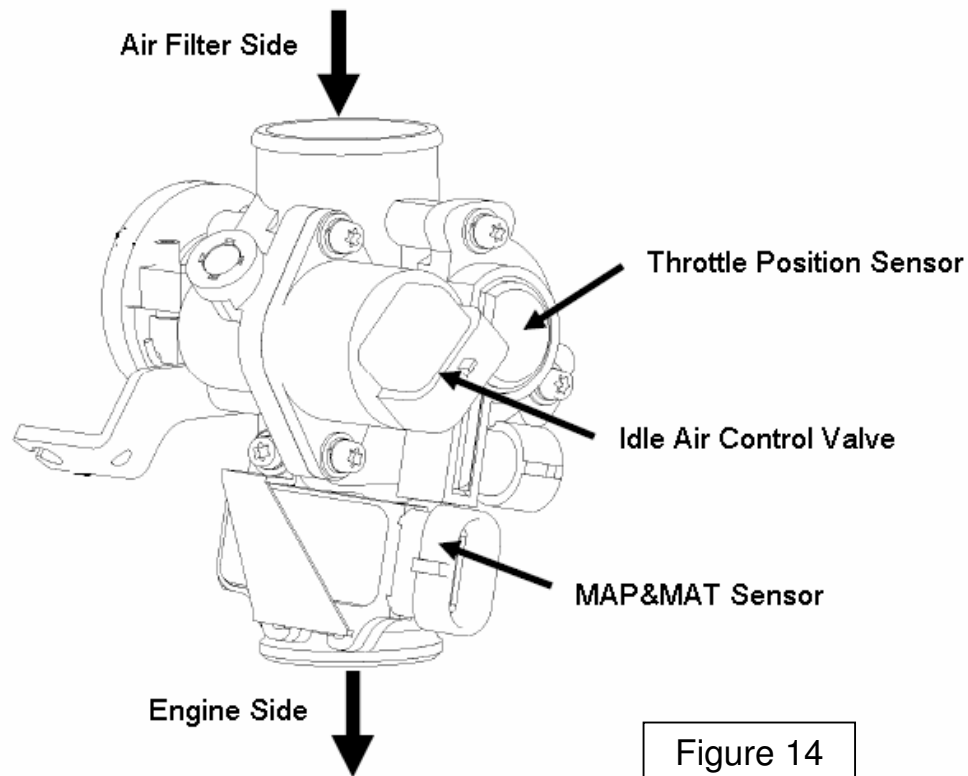

Figure 14

The appearance of the throttle body with stepper motor is shown in the figure 14 as above.

2.4.4. Technical Parameters

Throttle Body:

- 28mm bore size: Max flow: $\geq 30\text{g/s @ } 2.7\text{kPa Vacuum}$;
- 34mm bore size: Max flow: $\geq 50\text{g/s @ } 2.7\text{kPa Vacuum}$
- Throttle body opening torque:
Idle status: $0.12 \pm 0.03\text{Nm}$
Full open: $0.32 \pm 0.05\text{Nm}$

Throttle Position Sensor:

- Reference voltage: $5 \pm 0.1\text{VDC}$
- Resistance between T1 and T2: $3\text{k} \sim 12\text{k} \Omega$

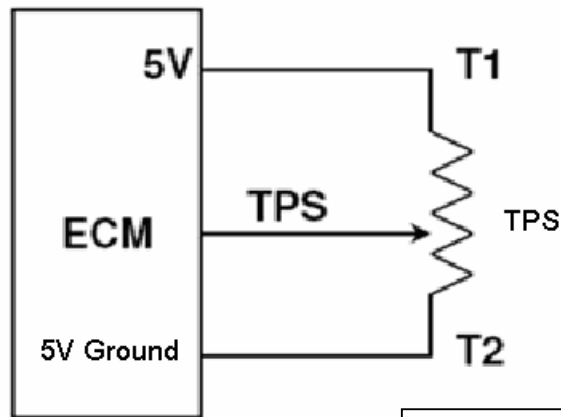

Figure 15

Idle Air Control Valve:

- Operating voltage: 7.5~14.2 VDC
- Solenoid resistance: $53 \Omega \pm 10\%$
- Solenoid inductance: $33\text{mH} \pm 20\%$

2.4.5. Operating Conditions

Normal Operating Temperature: -30~120°C

2.4.6. Throttle Body Removal

- Disconnect negative terminal of the battery
- Disconnect electric lead wire of throttle position sensor coupler, stepper motor coupler and MAP/MAT sensor coupler (if this sensor is mounted on the throttle body)
- Disconnect accelerator cable from throttle body
- Remove air cleaner outlet hose and throttle body outlet hose

2.4.7. Cleaning Procedure

If there is cover on the bottom, it may be removed and cleaned using carburetor cleaner (3M make recommended). Once the throttle body cover is removed, spray the throttle-body cleaner inside the shipping air passage, and use the brushes to gently dislodge the dirt, gum and varnish that are present. Do not let the by pass holes be blocked by dirt or foreign particles.

2.4.8. Throttle Body Installation

Reverse the procedure for installation noting the following:

- Adjust accelerator cable play

- Check to ensure that all removed parts are back in place.
- Reinstall any necessary part which have not been reinstalled

2.4.9. Precautions

- Do not submerge TPS in any cleaning fluid.
- Always open the throttle valve using the throttle cable or lever.
- Do not hold the valve at opening position by inserting tools or any sticks into the bore. The valve may be warped and the bore may be scratched. This type of damage may keep the throttle from opening easily or fully closing.

2.4.10. Handling – DOs and DONTs

THROTTLE BODY ASSEMBLY HANDLING		Table: 9
ACTION	REASON	
DO: Use care during assembly of harness to throttle body.	Avoid terminal damage.	
DO: Avoid any liquid contamination in the throttle body area.	Ensure proper operation.	
DO: Unload and install units one at a time from packing trays.	Damage may be done to critical components.	
DO: Return any dropped, damaged, or suspect material with a tag that describes the problem. (Only warranty cases)	Ensure fast and correct diagnosis of root cause.	
DO: Remove and discard protective caps just before assembling mating components.	Protects system from contamination, which can prevent proper operation.	
DO: clean the by pass passage after removing bottom cover	To ensure good idle stability	
DO NOT: Use any dropped or impacted unit.	Internal damage may have occurred or emissions settings may have been upset.	
DO NOT: Store units without protective caps in place.	Contamination may impair correct operation.	
DO NOT: Ship or store near saltwater without protection.	Corrosion buildup may impact proper operation.	
DO NOT: Exposed to environmental conditions (Moisture) prior to complete vehicle installation.	Corrosion buildup may impact proper operation.	
DO NOT: Apply any voltage other than system voltage for testing.	Damage could occur.	
DO NOT: Apply excessive band clamp loading	Damage could occur.	
DO NOT: Remove packing in a way that allows contact between parts.	Minimum air leakage could be affected and/or other damage could occur.	
DO NOT: Release the throttle cam abruptly from any position without the throttle linkage attached.	Damage could occur.	
DO NOT: Let the by pass holes be blocked by dirt or foreign particles.	This could effect idle stability	
DO NOT: Rake, stage, or handle parts in a manner that allows contact between parts.	Damage will occur.	

2.5. Throttle Body Assembly(w/o stepper motor)

2.5.1. Part List

Throttle Body Assembly Part List		Table: 10
Part Name	Remarks	
Throttle Body		
Throttle Position Sensor		
Idle By-pass Screw		

2.5.2. Description and Working Principle

The Throttle Body Assembly is an interactive system comprised of the following subsystems: the main casting body, bearing system, shaft and valve system, return spring system, cable interface system, throttle position sensing system, and the bypass air control system. The subsystems interact and support each other to provide all the functional requirements, which are mentioned below -

- Control intake air flow
- Control idle air flow
- Sense throttle position - Provide position feedback to Engine Controller
- Provide reactionary force to the throttle

2.5.3. Appearance

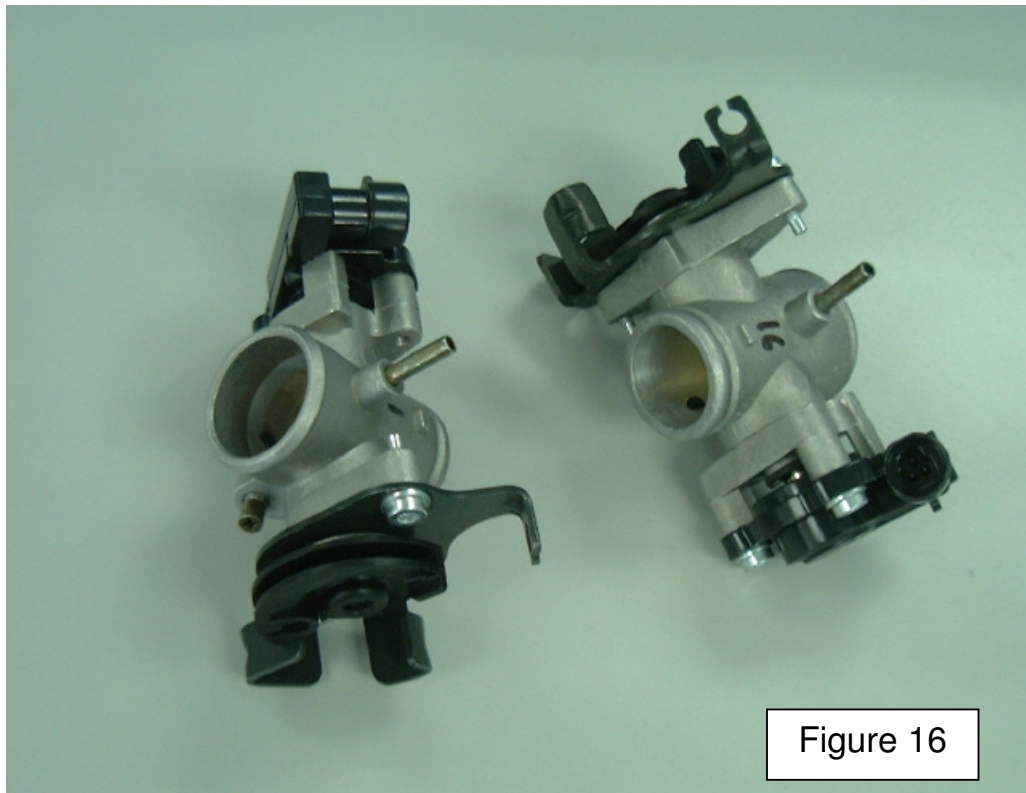

Figure 16

The appearance of the throttle body without stepper motor is shown in the figure 16 as above.

2.5.4. Technical Parameters

Throttle Body (bore size: 26mm):

- Throttle body max flow: $17.29 \pm 1.0 \text{g/s}$ @ 0.75kPa Vacuum
- Throttle body opening torque:
Idle status: $0.19 \pm 0.05 \text{Nm}$
Full open: $0.37 \pm 0.10 \text{Nm}$

Throttle Position Sensor:

- Reference voltage: $5 \pm 0.1 \text{VDC}$
- Resistance between T1 and T2: 3k~12k Ω

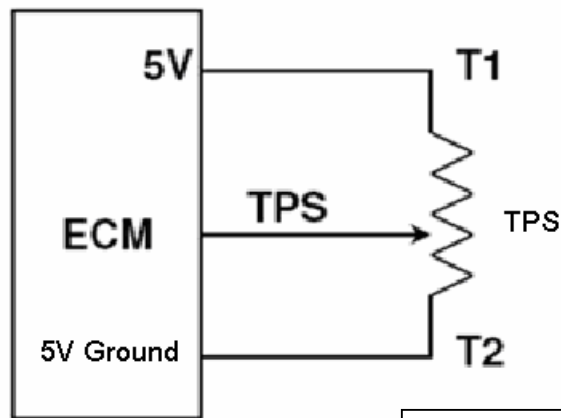

Figure 17

2.5.5. Operating Conditions

Normal Operating Temperature: -40~125°C

2.5.6. Throttle Body Removal

- Disconnect negative terminal of the battery
- Disconnect electric lead wire of throttle position sensor coupler
- Disconnect accelerator cable from throttle body
- Remove air cleaner outlet hose and throttle body outlet hose

2.5.7. Cleaning Procedure

If there is graphite coating, the graphite coating (black coating on the inside on the throttle body bore and valve) on the throttle bore **should not** be removed or cleaned on the vehicle. However the cover on the bottom may be removed and cleaned using carburetor cleaner (3M make recommended). Once the throttle body cover is removed, spray the throttle-body cleaner inside the shipping air passage, and use the brushes to gently dislodge the dirt, gum and varnish that are present. Do not let the bye pass holes be blocked by dirt or foreign particles.

If idle screw assembly is also removed for cleaning, then follow the below procedure for Idle screw assembly:

- Assemble the O-ring1 to Idle By-pass screw
- Assemble the spring, washer & O-ring 2 to Idle By-pass screw
- Assemble the above Idle By-pass screw sub-assy. to Throttle Body

After cleaning and idle screw assembly, use the diagnostic tool to set the idle rpm.

Note: Use fresh O-rings every time on re-assembly.

2.5.8. Throttle Body Installation

Reverse the procedure for installation noting the following:

- Adjust accelerator cable play
- Check to ensure that all removed parts are back in place.
- Reinstall any necessary part which have not been reinstalled

2.5.9. Precautions

- Do not submerge TPS in any cleaning fluid.
- Always open the throttle valve using the throttle cable or lever.
- Do not hold the valve at opening position by inserting tools or any sticks into the bore. The valve may be warped and the bore may be scratched. This type of damage may keep the throttle from opening easily or fully closing.
- Maintain factory set idle shipping air rate by keeping the allowed carbon around the throttle valve and bore
- Don't adjust idle screw position
- Replace the "o"rings after removal

2.5.10. Handling – DOs and DONTs

THROTTLE BODY ASSEMBLY HANDLING		Table: 11
ACTION	REASON	
DO: Use care during assembly of harness to throttle body.	Avoid terminal damage.	
DO: Avoid any liquid contamination in the throttle body area.	Ensure proper operation.	

DO: Unload and install units one at a time from packing trays.	Damage may be done to critical components.
DO: Return any dropped, damaged, or suspect material with a tag that describes the problem. (Only warranty cases)	Ensure fast and correct diagnosis of root cause.
DO: Remove and discard protective caps just before assembling mating components.	Protects system from contamination, which can prevent proper operation.
DO: clean the bye pass passage after removing bottom cover	To ensure good idle stability
DO: replace 'o' rings on the idle screw if it is dismantled	To ensure there is no air leakage from the worn or damaged 'o' rings
DO NOT: Use any dropped or impacted unit.	Internal damage may have occurred or emissions settings may have been upset.
DO NOT: Store units without protective caps in place.	Contamination may impair correct operation.
DO NOT: Ship or store near saltwater without protection.	Corrosion buildup may impact proper operation.
DO NOT: Exposed to environmental conditions (Moisture) prior to complete vehicle installation.	Corrosion buildup may impact proper operation.
DO NOT: Apply any voltage other than system voltage for testing.	Damage could occur.
DO NOT: Apply excessive band clamp loading	Damage could occur.
DO NOT: Remove packing in a way that allows contact between parts.	Minimum air leakage could be affected and/or other damage could occur.
DO NOT: Release the throttle cam abruptly from any position without the throttle linkage attached.	Damage could occur.
DO NOT: Let the bye pass holes be blocked by dirt or foreign particles.	This could effect idle stability
DO NOT: Rake, stage, or handle parts in a manner that allows contact between parts.	Damage will occur.

2.6. Engine Coolant Temperature Sensor (For Water Cooled Engine)

2.6.1. Part List

ETS Part List		Table: 12
Part Name	Remarks	
Engine Coolant Temperature Sensor	Common to all applications	

2.6.2. Description and Working Principle

This sensor is used in water cooled engines. It provides a resistance that varies as a function of temperature within prescribed tolerance limits. The sensor has a negative temperature coefficient of resistance. This is a non-serviceable part.

2.6.3. Appearance



Figure 18

The appearance of the Engine Coolant Temperature Sensor is shown in the figure 18 as above.

2.6.4. Installation Requirements

- **Dynamic Torque Requirement:** The sensor shall be hand into the application and then driven by a driver with a maximum no load speed of 400 rpm or installed to the desired torque by a hand torque wrench (5/8" hex). The recommended installation torque is:
 - Minimum: 20 N·m
 - Maximum: 25 N·m
- **Static Torque Requirement:** The torque required to remove the sensor from the mating hole shall be within 200% of the installation torque mentioned above.

2.6.5. Operating Environment

- This device is intended for use in engine coolant and air cooled applications and shall withstand such an under hood environment.
- **Normal Operating Temperature:** -40 °C ~ 135 °C (continuously).
- **Relative Humidity:** 0 to 100% RH.
- **Typical Pressure:** When installed at the minimum torque the sensor shall be capable of sealing engine coolant with a positive pressure of 206.8 kPa (30 psi) at 135 °C applied to the probe tip end of the sensor.
- **Extreme Operating Environment:** Maximum temperature excursion to 150 °C for 1 hour.

2.6.6. Storage Environment

- **Storage temperature:** -40 °C to 120 °C for an indefinite duration
- **Transport at altitudes to:** 13,700 m for an indefinite duration

2.6.7. Electrical Environment

- Typical Voltage: The sensor circuit operates with a DC voltage reference of 5 ± 0.1 VDC.
- Maximum Excitation Current: The sensor calibration shall not be affected by a current source of less than 1 mA at all temperatures.

2.6.8. Sample Cleaning

- When necessary the samples may be cleaned in isopropyl alcohol for one minute with mating connectors in place and then air-dried

2.7. Engine Temperature Sensor (For Air Cooled Engine)

2.7.1. Part List

ETS Part List		Table: 13
Part Name	Remarks	
Engine Temperature Sensor	Common to all applications	

2.7.2. Description and Working Principle

This sensor is used in air cooled engines. It provides a resistance that varies as a function of temperature within prescribed tolerance limits. The sensor has a negative temperature coefficient of resistance. This is a non-serviceable part.

2.7.3. Appearance

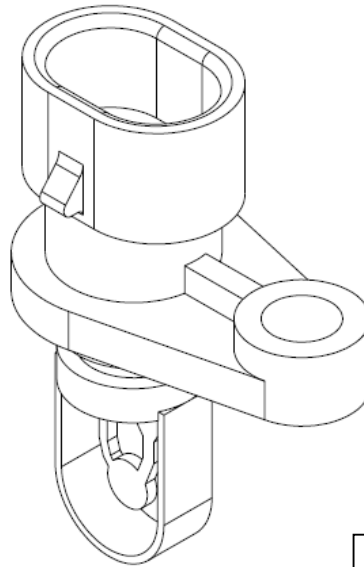

Figure 19

The appearance of the Engine Temperature Sensor is shown in the figure 19 as above.

2.7.4. Installation Requirements

- Recommend to put the washer and spring gasket between bolt and sensor before assembly.
- Mounting Torque Requirement: 4~6Nm.

2.7.5. Electrical Environment

- Typical Voltage: The sensor circuit operates with a DC voltage reference of 5 ± 0.1 VDC.

2.7.6. Sample Cleaning

- When necessary the samples may be cleaned in isopropyl alcohol for one minute with mating connectors in place and then air-dried

2.8. Intake Air Temperature Sensor (MAT)

2.8.1. Part List

MAT Part List		Table: 14
Part Name	Remarks	
Intake Air Temperature Sensor	Common to all applications	

2.8.2. Description and Working Principle

This sensor provides a resistance that varies as a function of temperature within prescribed tolerance limits. The sensor has a negative temperature coefficient of resistance. This is a non-serviceable part.

2.8.3. Appearance

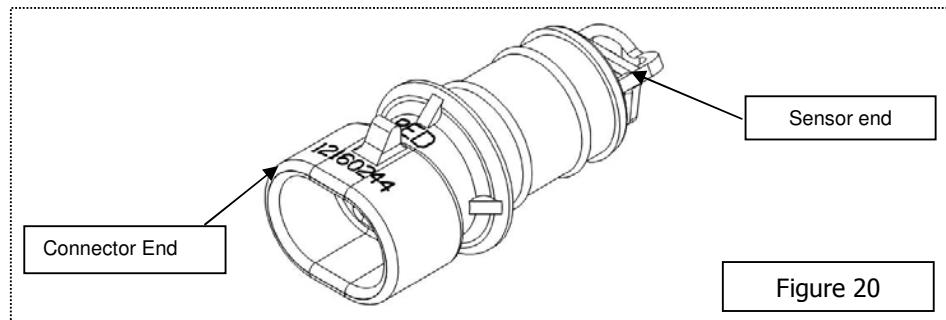

The appearance of the Engine Temperature Sensor is shown in the figure 20 as above.

2.8.4. Technical Parameters

- Operating Voltage: 5VDC
- Response Time: <15s
- Operating Temperature: -40 ~ 150°C
- Relative Humidity: 0 to 100% RH.

2.8.5. Installation Requirement

- Recommend Diameter of Mounting Hole: 12mm
- Recommend Depth of Mounting Hole: $\geq 12\text{mm}$ & $\leq 16\text{mm}$
- Mounting Angle with Level: >15degree

2.8.6. Sample Cleaning

- When necessary the samples may be cleaned in isopropyl alcohol for one minute with mating connectors in place and then air-dried

2.9. Intake Air Pressure and Temperature Sensor (MAP&MAT)

2.9.1. Part List

MAP&MAT Part List		Table: 15
Part Name	Remarks	
Intake Air Pressure and Temperature Sensor		

2.9.2. Description and Working Principle

This sensor has two functions. The first is the intake manifold air temperature, it provides a resistance that varies as a function of temperature within prescribed tolerance limits. The second is the intake manifold air pressure; it provides a voltage varies as the intake air pressure.

2.9.3. Appearance



Figure 21

The appearance of the MAP&MAT Sensor is shown in the figure 21 as above.

2.9.4. Operating Environment

- This device is intended for use in inlet manifold for sensing air temperature and pressure which shall withstand such an under hood environment.
- Pressure Range: 20~102kPa
- Temperature Range: -40~105 °C
- Relative Humidity: 0 to 100% RH.
- Extreme Operating Environment: Maximum temperature excursion to 125 °C for 2 hours.

2.9.5. Storage Environment

- Storage temperature: -50 °C to 150 °C for an indefinite duration

2.9.6. Electrical Environment

- Typical Voltage: The sensor circuit operates with a DC voltage reference of 5 ± 0.1 VDC.

2.9.7. Sample Cleaning

- When necessary the samples may be cleaned in isopropyl alcohol or gasoline for one minute with mating connectors in place and then air-dried

2.10. Oxygen Sensor

2.10.1. Part List

Oxygen Sensor Part List		Table: 16
Part Name	Remarks	
Oxygen Sensor		

2.10.2. Description and Working Principle

This sensor is a device for monitoring the residual oxygen in the exhaust of an internal combustion engine. It consists of the wide range sensor and stoichiometric sensor. Usually we use stoichiometric sensor on the small engine. It is the feedback element for engine closed loop control.

2.10.3. Appearance

The appearance of the Engine Oxygen Sensor is shown in the figure 22 as below.

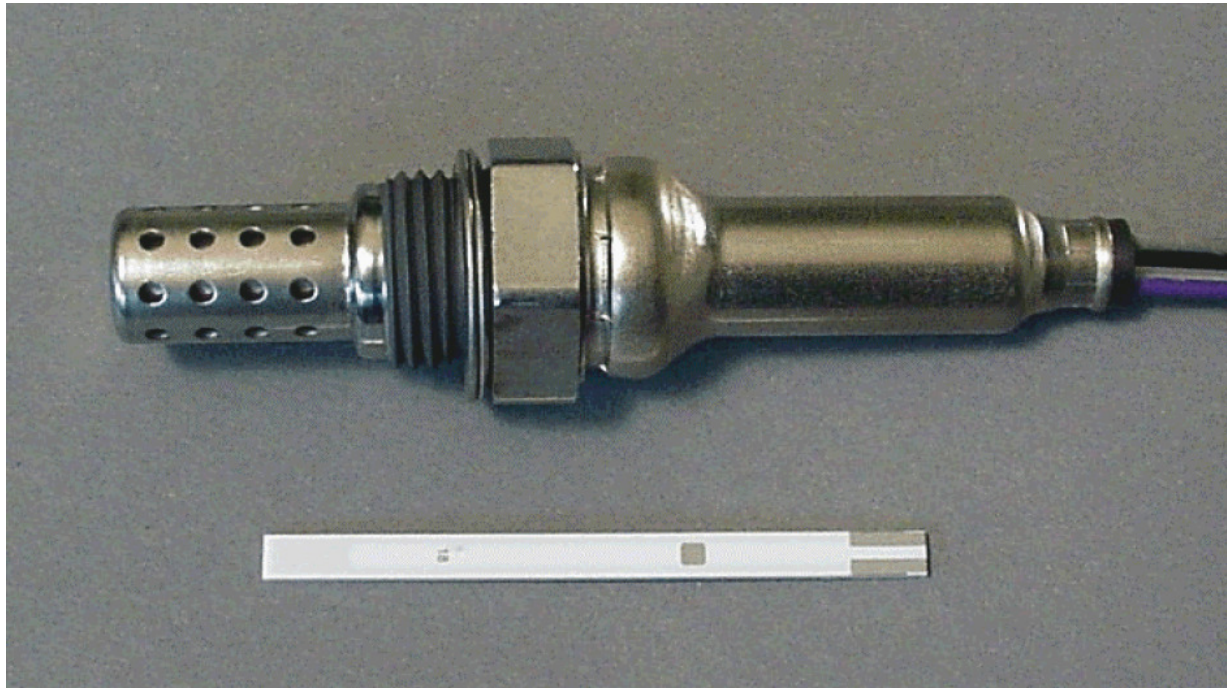

Figure 22

2.10.4. Technical Parameters

- A/F ratio rich threshold: >750 mVDC
- A/F ratio lean threshold: <120 mVDC
- Heater power: 7.0W
(These parameters as above are measured basing on 450°C (engine dyno), typically on 70% duty at 10Hz and under 13.5V)
- Heater part resistance: $9.6 \pm 1.5 \Omega$
(This parameter is measured basing on 21°C)
- Operating temperature range: $260\text{-}850^{\circ}\text{C}$

2.10.5. Installation Requirements

- Mounting Angle with Level: ≥ 10 degree

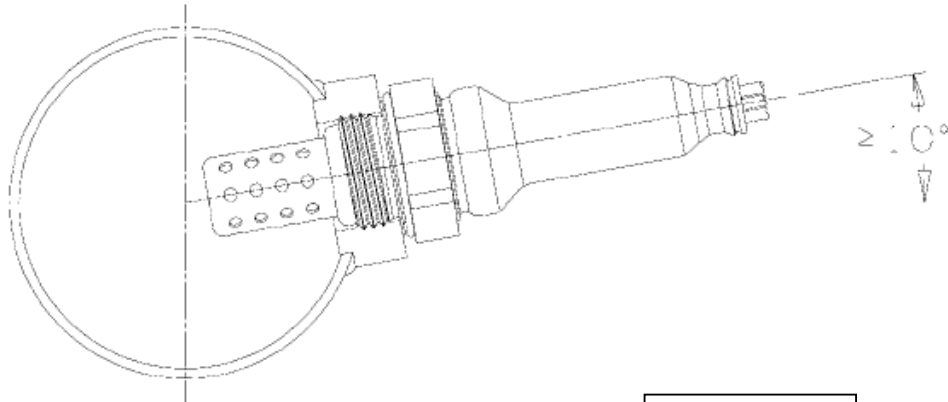

Figure 23

- Tightening Torque Requirement: 40-60 Nm

2.10.6. Fuel Quality Requirements

- $Pb \leq 0.005g/L$
- $P \leq 0.0002g/L$
- $S \leq 0.04\%$ (weight proportion)x
- $MMT \leq 0.0085g/L$
- $Si \leq 4ppm$

2.11. Ignition Coil

2.11.1. Part List

Ignition Coil Part List		Table: 17
Part Name	Remarks	
Ignition Coil W/O Connector		
Ignition Coil With Connector		

2.11.2. Description and Working Principle

This coil provides energy to the spark plug in the combustion chamber. The coil itself doesn't have a driver. The high voltage tower of the coil is connected to the spark plug using a high voltage cable assembly. This is a non-serviceable component.

2.11.3. Appearance

The appearance of the Ignition coil is shown in the figure 24 as below.

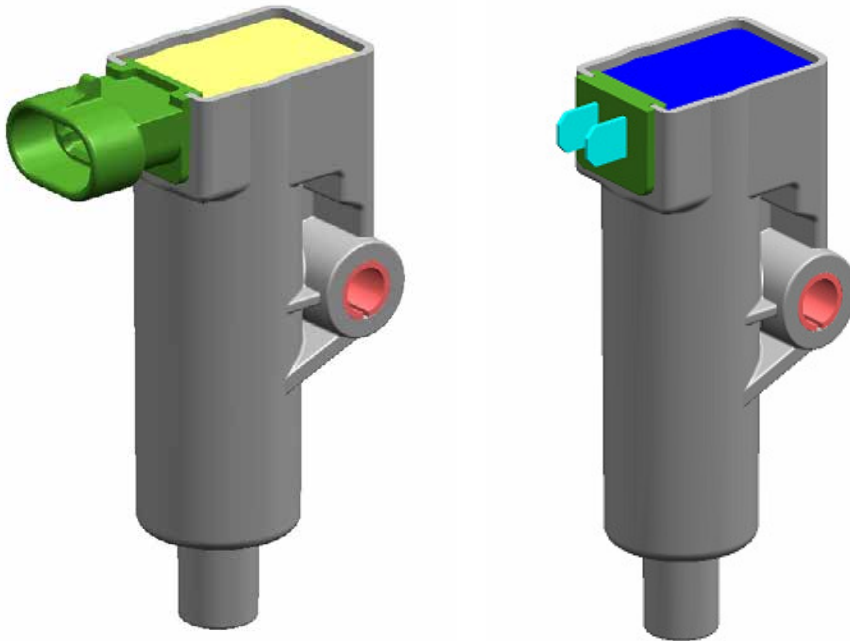

Figure 24

2.11.4. Technical Parameters

- Input voltage: 9~14VDC
- Output voltage: ~25~30KV
- Operating temperature: -30 ~110 °C
- Storage temperature: -40~155°C
- Mounting Torque: 8.8~11.8Nm

2.11.5. Installation requirements

- The vehicle frame provides the mounting surface and mounting holes.
- Mount coil close to the spark plug and keep the plug wire length very short (less than 6 ").
- Mount coil away from any pick coil device. Especially, a VR type Crank / Cam sensor. Keep a Min distance of 150 mm (around 6") between coil and any VR sensor device.
- Never route the coil C- wire with the same bundle as the Crank sensor wires. There is around 200 V peak potential between C- wire and engine ground. This voltage potential could cause a noise on sensor cables.

2.11.6. DOs and DONTs

Ignition Coil Handling		Table:18
Action	Reason	
DO NOT: Install the low voltage connectors with the power applied	This might cause an unwanted secondary firing, possibly leading to personal injury	
DO NOT: Use a screw driver to asset in removing secondary boots from the secondary tower. Use tools designed for secondary removal.	It is possible to damage a secondary lead in such a manner that creates an electrical path to outside the system permitting improper system operation misfire, or even possible personal injury if arcing occurs.	
DO NOT: Use parts that have been dropped or display physical damage	Damaged components can lead to premature failure.	
DO NOT: Scratch or apply any non approved material to the surface of the high voltage tower which mates with the high voltage secondary leads.	This can jeopardize the seal integrity of the mating surfaces which in turn can create a secondary high voltage leak path.	
DO NOT: Strike any part of the ignition system with a tool or other object.	This can lead to physical damage which can cause a system malfunction or failure.	
DO NOT: Permit paint or other sprayed materials to be sprayed onto the electrical connectors.	Insulating type sprays can create a high resistance or open connection. And, a conductive type spray can create an electrical short condition.	
DO NOT: Support the ignition system by the wiring harness or plug wire.	These leads are not designed to support the weight of the ignition system. It can create a poor electrical connection Or become disconnected allowing the system to fall and be subjected to physical damage	
DO NOT: Pierce or probe the secondary leads.	This creates an electrical path to outside the system permitting improper system operation, misfire, or even possible personal injury if arcing occurs.	
DO NOT: Operate without the spark plug attached.	If a technician or mechanic comes in contact with the high voltage generated during operation, personal injury may occur. Or, if the engine is operated under this condition, unburned fuel may fill the converter area creating a potential hazard	
DO NOT: Share ignition component wiring with other components, Dedicated wiring is required.	This prevents electrical cross talking between components which can lead to component malfunction.	
DO NOT: Apply voltage to the ignition system other than vehicle system voltage for testing purposes.	This can cause reduced performance or an electrical malfunction of the ignition system.	
DO NOT: Use high impact tools to apply the spark plug boot to the ignition secondary towers. Installation of the high voltage secondary leads by hand is preferred.	Damage to the coil tower, secondary boot, or mating connection surfaces might occur.	
DO: Install the secondary leads before connecting the primary leads.	In the event the low voltage connection has been made and the power applied, unwanted secondary output might occur possibly resulting in injury, damage the ignition component, and test equipment	
DO: Take care when working around the ignition system.	The high voltage produced by the coil secondary circuit can cause personal injury and/or damage test equipment	
DO: Proper handling and shipping methods need to be in place to reduce the risk of damage due to impact, moisture, or contamination	Damaged components can lead to premature failure.	
DO: Avoid unnecessary disconnecting and connecting of the electrical components.	The electrical connections are not designed for repeated connection and disconnection.	
DO: Insure the low voltage connectors are entirely seated and the locking mechanism is engaged.	This prevents intermittent electrical connections leading to an improper ignition system operation.	
DO: Use approved connector breakouts when testing the ignition system.	Connector and/or component damage may occur.	

DO: Insure the appropriate seals are included in the connector system.	Liquid intrusion into the terminal connection area might occur causing an electrical intermittent or short condition. In the event of severe terminal corrosion, an open condition might occur.
DO: Operate with gasoline based internal combustion engines.	Other fuels or combustion designs may require additional design considerations.
DO: The power feed line should be fused.	This could protect the system in the event of an electrical short
DO: The module heat sink and back plate must not be used as a connection point when jump starting the engine	The high level of voltage and current which the module could be subjected to, could cause module performance degradation or failure.
DO: Connection of the module back plate to vehicle ground is desirable whenever possible	This greatly reduce potential ground loops and acts as a heat transfer source from the module.
DO: The ignition system ground wire should be kept as short as possible. And, when permissible, should be grounded at the same engine block position as the engine controller	This would greatly reduce the possible of unwanted electrical ground loops.
DO: The electrical wiring to the ignition system should be routed so that the conductors are protected from excessive heat, damage, and wear.	Helps prevent electrical intermittent, open or shorted operating conditions.
DO: Ignition secondary leads should not be routed with the ignition primary harness or any other electrical harness.	Voltage spikes can be transmitted from the secondary cables into other leads which are in close. This could create a component performance degradation or failure condition
DO: Spark plug wires(secondary leads) & primary wiring: - must not contact sharp surface - must not be under tension between fixed points - must be clear of moving parts (belts, fan, etc...) - must be protected from or kept at least 125 mm away from radiant heat source exceeding 400 F. - must be protected from environmental damage (dirt, splash, oils, fluids, etc...) - must be retained, secured or insulated to prevent pinching, mis-routing, rattles, and squeaks	- Spark plug wires carry very high voltage (30,000 volt). If the secondary lead loses its dielectric characteristics thru being nicked, cut , chaffed, then an arc thru to a near by ground could take place. This kind of condition could lead to misfire, no start, or premature failure of ignition system.
DO: Not all fasteners are designed for repeat use. Beware of fastener specifications. All harnesses should be supported within 6" of a mating connection.	Adequate retention force might not be achieved if the fastener is not designed to be reused. Mating connections are not designed to support the weight of the harness assembly.
DO: For removing spark plugs follow the following steps: 1- Grasp the spark plug boot and gently rotate 90°; and then pull the spark plug boot and cable away from the spark plug 2- Before removing spark plug, brush or air blast dirt away from the well areas 3- Use correct size deep socket wrench to loosen each spark plug one or two turns	To remove spark plugs from Aluminum heads, allow the engine to cool. The heat of the engine, in combination with a spark plug that is still hot, may cause the spark plug threads to strip the cylinder head upon removal Use goggles to protect eyes from dirt when applying compressed air to spark plug wells
DO: Cleaning a spark plug could be done as follow: 1- wipe all spark plug surfaces clean....remove oil, water, dirt and moist residues. 2- If the firing end of spark plug has oily or wet deposit, brush the spark plug in an approved, non-flammable and non-toxic solvent. Then dry the spark plug thoroughly with compressed air 3- Use a propane torch to dry wet-fuel fouled plugs.	- Cleaning a spark plug will reduce the voltage required for an electrical arc(spark) across the electrodes - Cleaning & re-gapping will not restore a used spark plug to a new condition. It may be more economical and efficient to replace used spark plugs with new plugs instead of cleaning. - Sooted plugs should be replaced - Do not cool by using water or any liquid - Clean threads permit easier installation and

<p>Allow the torch flame to enter up the center electrode insulator. Allow plug to cool down</p> <p>4- If the spark plug threads have carbon & scale deposits, clean with wire brush, taking care not to injure the electrode or the insulator tip</p>	<p>proper seating which will maximize transfer heat away from the plug</p>
<p>DO: Regap spark plugs to the exact measurement specified by the engine manufacturer to keep the best fuel economy and proper engine performance</p> <ul style="list-style-type: none"> - Use round wire-type gauge for an accurate measure of gap on all used spark plugs - when gapping a spark plug only the side electrode is moved. The center electrode must not be moved 	<ul style="list-style-type: none"> - Too wide a gap could cause the plug to misfire(higher required ignition voltage). - Too narrow of a gap could affect idle stability - A flat gauge can't accurately measure the spark plug on used plugs
<p>DO: When replacing spark plugs with new ones, always use equivalent plugs with same heat range, thread, size, etc....</p>	<ul style="list-style-type: none"> - Higher heat range plug(hotter plug) could lead to pre-ignition & possible piston damage - Lower heat range (colder plug) could lead to cold fouling & emission problem
<p>DO: For installing spark plugs follow the following steps:</p> <ol style="list-style-type: none"> 1- make sure the cylinder head threads and spark plug threads are clean. Make sure the spark plug thread is free of dings and burrs. If necessary, use a thread chaser and seat cleaning tool. 2- Make sure the spark plug gasket seat is clean, then thread the gasket to fit flush against the gasket seat. Tapered seat plugs do not require gaskets 3- Screw the spark plugs finger-tight into the cylinder head. Then, use a torque wrench to tighten spark plugs following manufacturer's recommendation). <p>Torque is different for various plug type & cylinder head material</p>	<ul style="list-style-type: none"> - If the thread is damage, it prevents a good heat transform from the shell to the cylinder head - Do not use any type of anti-seize compound on spark plug threads. Doing this will decrease the amount of friction between the threads. The result of the lowered friction is that when the spark plug is torqued to the proper specification, the spark plug is turned too far into the cylinder head. This increases the likelihood of pulling or stripping the threads in the cylinder head - Over-tightening of a spark plug can cause stretching of the spark plug shell and could allow blowby to pass thru the gasket seal between the shell and insulator. Over-tightening also results in extremely difficult removal

2.12. Evaporative Canister Purge (ECP)

2.12.1. Part List

ECP Part List		Table: 19
Part Name	Remarks	
Evaporative Canister Purge		

2.12.2. Description and Working Principle

The evaporative canister purge system controls the release of fuel vapors from the vapor collection canister into the engine intake manifold, so that they are burned in the combustion process. We can reduce the evaporative emission through this system.

2.12.3. Appearance

The appearance of the ECP is shown in the figure 25 as below.



Figure 25

2.12.4. Technical Parameters

- Operating voltage: 8-16 VDC
- Operating temperature: -40 - 120 °C
- Typical operating frequency: 16Hz
- Max flow: 25-35L/min

- Flow curve as below figure 26:

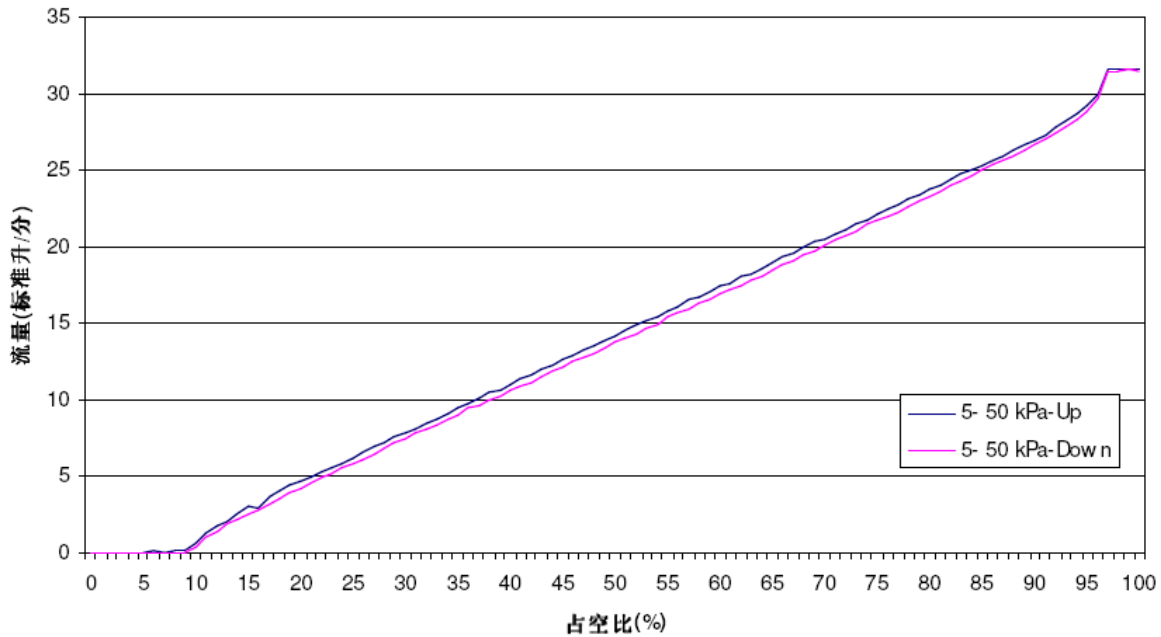

Figure 26

2.12.5. Installation requirements

- The ECP should be mounted on the bike's frame horizontally
- The ECP should be close to the axis of the crank shaft so as to reduce the vibration.

2.13. Fuel Pump Module

2.13.1. Part List

Fuel Pump Module Part List		Table: 20
Part Name	Remarks	
Fuel Pump Module Assembly		
Fuel Pump Kit		
Fuel Pressure Regulator Kit		
Gasket, Fuel Module		

2.13.2. Description and Working Principle

Fuel Pump Module supplies fuel to engine at system pressure. Fuel Pump Module is mounted to fuel tank at bottom and supplies fuel to engine through hoses.

Fuel Pump module consists of Fuel Pump to generate the fuel flow and pressure regulator to regulate the fuel pressure.

Fuel Pump

When power is supplied to fuel pump, motor in pump assembly rotates the impeller. Impeller in turn draws the fuel from strainer and pumps the flow to generate the system pressure.

Pressure Regulator

Pressure Regulator is a diaphragm type mechanical device. Fuel flow from filter enters in the inlet of pressure regulator. Pressure regulator regulates the fuel pressure at a set pressure by releasing the excessive fuel flow to fuel tank.

2.13.3. Appearance & Components of Fuel Module

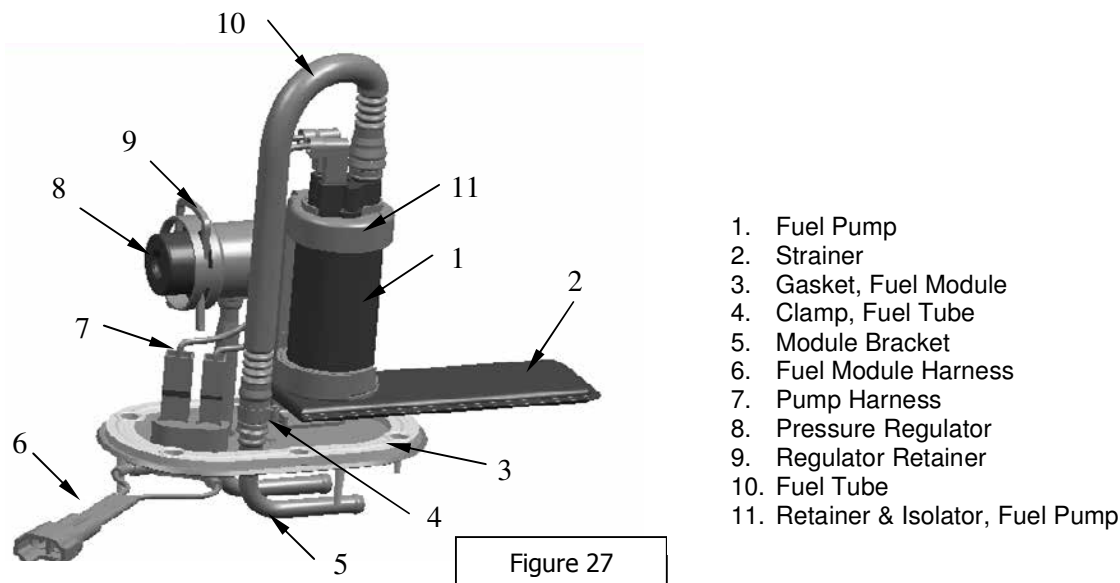

2.13.4. Dimensions

Fuel Module Cover in elliptical shape with outer edge dimensions as 115mm x 70mm.

Fuel Module Height from Cover to the Fuel Tube top portion is 135mm (reference value).

2.13.5. Identification and Markings

Fuel Module, Fuel Pump and Regulator are marked with batch code in Julian Date Code.

On Fuel Module, batch code is mentioned on the label available on fuel module cover.

On Fuel Pump Batch code is engraved on pump body (shell).

On Fuel Pressure Regulator, batch code is engraved on regulator dome area.

2.13.6. Operating Conditions

- Fuel Pump Module needs to be mounted on Fuel Tank Bottom according to the installation instructions.

- Fuel Pump Module is intended to use with gasoline. However if the fuel contains ethanol, please contact vehicle manufacture to check whether the fuel pump module itself can survive or not.
- Make sure there is at least 3 liters of gasoline in the fuel tank before priming for first time (do not run the pump dry)
- Fuel Hose connections needs to be installed according to the fuel flow diagram shown in Figure 28

Fuel Flow Description in vehicle fuel system

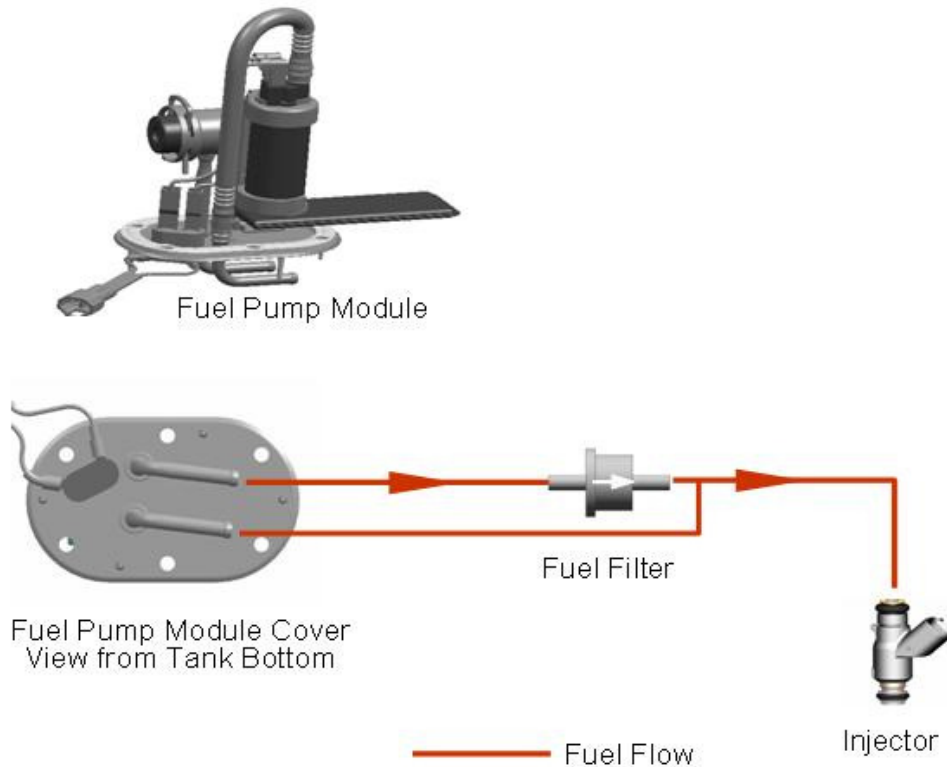

Figure 28

2.13.7. Service Parts:

Fuel Pump Module
Part Number: 28061389



Figure 29

Fuel Pump Kit
Part Number: 28094405

1. Fuel Pump Assembly (Fuel Pump + Strainer + Fuel Tube)
2. Clamp, Fuel Tube
3. Gasket, Fuel Module
- 4.

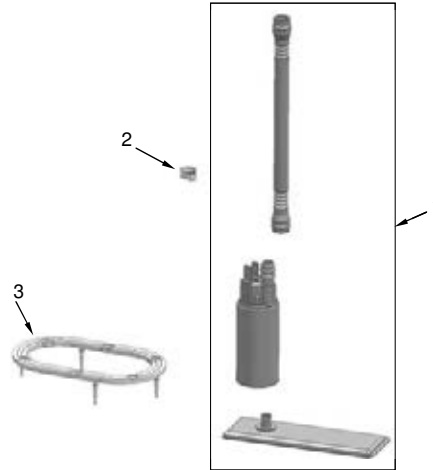

Figure 30

Pressure Regulator Kit
Part Number: 28094406

1. Pressure Regulator Assembly
2. Gasket, Fuel Module

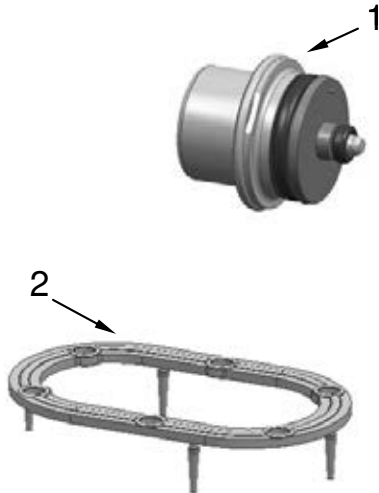

Figure 31

Gasket, Fuel Module
Part No: 28063208

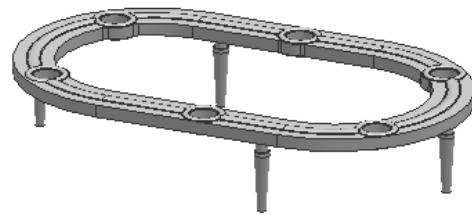

Figure 32

2.13.8. Service Procedure:**Precautions:**

Before attempting any service on fuel system, following cautions should be always followed for personal safety and to avoid system damages.

- Disconnect negative cable at battery.
- DO NOT smoke, and place 'No SMOKING' sign near work area
- Make sure to have fire extinguisher handy.
- Make sure to perform work in well ventilated area and away from any open fire/flames.
- Wear Safety glasses
- To relieve fuel vapor pressure in fuel tank, remove fuel filler cap fuel filler neck and then reinstall it.
- As fuel lines are at high pressures when the engine is stopped, loosening or disconnecting fuel line will cause dangerous spout of fuel. Before loosening/ disconnecting fuel lines, please follow the "Fuel Pressure Relief Procedure" described in this section.
- Small amount of fuel may drip after the fuel lines are disconnected. In order to reduce the risk of personal injury, cover the pipe/ hose ends with suitable blind with no rust or contamination.
- After servicing, make sure that the fuel hoses and clamps are connected according to the hose fitment instructions given in vehicle instruction manual.
- After servicing, please follow the 'Fuel Leakage Check Procedure' described in this section.
- After servicing make sure to fill at least 3 liters gasoline before pump is primed (ignition key should be turned on only after ensuring there is minimum 3 liters of fuel in the fuel tank)

Fuel Module Diagnosis:

Step	Action	Yes	No
1	Switch on Ignition key. Fuel Pump primes for 3 seconds when the ignition key is ON. Check for fuel pump running noise for 3 seconds after ignition key is ON.	If fuel pump running noise can be heard, go to step 4.	If fuel pump running noise can not be heard, go to step 2.
2	Disconnect fuel module coupler. Check voltage at harness coupler. Is the voltage within 10-14V?	Go to step 3	Check the electrical circuit from Ignition to fuel module.
3	Connect 12V DC power supply (battery) to fuel module. Make sure that enough fuel available in fuel tank to avoid fuel pump running dry. Is the fuel pump running?	1. Check electrical circuit from fuel module to ECU 2. Check ECU	1. Check Fuel Pump Harness integrity 2. Check Fuel Pump

4	Check fuel system pressure at Injector inlet (with a T-joint) while engine is running in idle condition. Is the pressure between 220 ~ 270kPa?	Fuel Module Operation Normal	Go to Step 5
5	Is the Pressure below 220kPa?	1. Check for leakages from hoses, hose joints 2. Check Fuel Pump 3. Check Pressure Regulator	1. Clogged Filter 2. Kink/ Blockage in Fuel Hoses 3. Check Regulator

Fuel Module Removal:

- Relieve fuel pressure in fuel lines referring to the 'Fuel Pressure Relief Procedure' provided in this section.
- Disconnect negative cable at battery.
- Disconnect fuel module wire coupler.
- Drain the fuel in fuel tank thru fuel filler with help of hand pump (siphon). Collect the fuel in approved container for contamination and safety.
- Disconnect the fuel hoses from fuel module by using standard tools
- Remove the fuel tank from vehicle.
- Place the fuel tank with bottom up condition. Care to be taken not to cause any scratches/ damages on fuel tank.
- Open the fuel module mounting bolts.
- Take out fuel module assembly from fuel tank with care
- Care to be taken not to damage the strainer while removing fuel module from tank.

Fuel Module Installation:

- Replace the fuel module gasket in fuel module assembly with a new one. Old/ used gaskets can cause leakages.
- Fold strainer towards fuel pump and insert fuel module in tank opening with care. Care should be taken not to cause any damages on strainer.
Fuel Module Orientation: Fuel module bolts not symmetrical and can be mounted only in the intended direction. Regulator side should be facing the Fuel Tank rear side.
Make sure that the fuel tank surface at module mounting area is clean and free of surface defects.
- Place the bolts on module cover and tighten the bolts gradually in star pattern sequence to apply equal compression on gasket. It is shown in figure 33 as below.
Bolt Tightening Torque: 3~4 Nm.
Fuel module is installed with special bolts (step bolts). Use designated bolts only.
Follow the tightening torque and tightening sequence instruction. Over torque and miss-sequence can cause unequal compression of gasket and leakage.
- Install the fuel tank to vehicle.
- Connect for fuel hoses with suitable hose clamps.
- Connect fuel module coupler.

- Follow “Fuel Leakage Check Procedure’ to check any leakage before the engine is started.

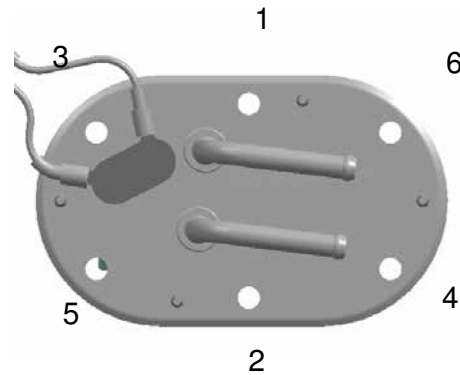

Mounting Bolts – Star Tightening Pattern

Figure 33

Pressure Regulator Assembly Replacement:

- Remove the regulator retainer from module.
- Apply gradual pull force on retainer to avoid any personal injury due to spring action of retainer.
- Take out the pressure regulator assembly from module.
- Do not hit/ damage on the regulator dome and crimping portion.
- Lubricate the O-rings in new pressure regulator assembly with recommended lubrication oils as mentioned in Table no: 3. Lubrication oil is applied only for ease of regulator assembly.
- Make sure that 2 O-rings (one is bigger diameter the other is smaller diameter) are assembled in pressure regulator.
- Place the pressure regulator on module at regulator pod. Push the regulator gently in the pod.
- Do not hit/ damage on the regulator dome and crimping portion. This will disturb the pressure setting.
- Assemble the retainer on the regulator pod
- Replace the gasket, module with new gasket provided in the kit.

Fuel Pressure Relief Procedure:

Caution: This work must not be done when engine is hot. If done so, it may cause adverse effect to catalyst (if equipped)

After making sure that engine is cold, relieve fuel pressure as follows.

- Place vehicle gear in ‘Neutral’.
- Disconnect fuel module electrical coupler from vehicle harness.
- Start engine and run till it stops due to lack of fuel. Repeat ignition key ON and OFF for 2 ~ 3 times of about 3 seconds each time to relieve fuel pressure in lines. Fuel Connections are now safe for servicing.
- Upon the completion of servicing, Connect Fuel Module Connector to Vehicle Harness.

Fuel Leakage Check Procedure:

After performing any service on fuel system, check to make sure that there are no fuel leakages as below.

- Fill about 3 ~ 5 liters of fuel in tank.
- Turn Ignition key to ON position for 3 seconds (to operate fuel pump) and then turn to OFF position. Repeat this for 3 ~ 4 times to apply fuel pressure in fuel lines.
- In this state, check to see that there are no fuel leakage from any part of fuel system (Fuel Tank, Hoses, Hose Joints, etc)

2.13.9.Handling – DOs and DONTs:

FUEL MODULE HANDLING		Table: 21
ACTION	REASON	
DO NOT: Drop Fuel Module on Floor	Could cause internal damage to Fuel Pump.	
DO NOT: Run Fuel Pump Dry (without fuel at pump inlet/ strainer) ensure atleast 3 litres of gasoline is present in the fuel tank	Caused internal damage to Fuel Pump	
DO NOT: Damage the strainer during servicing, insertion of fuel module in fuel tank	Contamination enters fuel pump thru damaged strainer damages the Fuel Pump	
DO NOT: Disassemble Fuel Pump and regulator internal parts out side Delphi premises. DO NOT: Do any adjustments on pressure regulator and pump except for replacement.	Warranty void.	
DO NOT: Use module harness for hold/ carry fuel module. DO NOT: Pull Wiring Harness in vertical direction to module cover	Wiring Harness Breakage/ Fuel Pump Power disconnection	
DO NOT: Use damaged/ distorted hose clamps.	Can cause fuel seepage/ leakage.	
DO NOT: Use Fuel Module if the strainer with excessive damage/ cut.	Contamination enters fuel pump thru damaged strainer damages the Fuel Pump	
DO NOT: Use Fuel Pump for draining fuel in fuel tank.	Not intended function of fuel module.	
DO NOT: Use module mounting bolts for mounting other components.	Affects fuel module sealing.	
DO NOT: Damage fuel pump harness while servicing fuel module.	Damaged terminals will cause intermittent/ No contact for power supply.	
DO NOT: Force hand pump towards fuel module while draining fuel from tank.	To avoid any damages on fuel module.	
DO : Ensure that there are no damages to fuel pipes while servicing fuel module	Can cause fuel seepage/ leakage.	
DO: Use genuine module gasket only.	Spurious gaskets can cause leakages.	
DO: Use designated hose clamps.	To ensure no leakages/ seepages thru hose joint.	
DO: Clamp fuel module harness to vehicle chassis	Clamp provides mechanical support for wiring harness in vibrations.	
DO: Use only standard gasoline for operating vehicle/ module.	Fuel Module is intended to run in standard gasoline. Adulterated fuel can cause fuel module premature failures which are not covered under warranty.	

DO: Change the fuel filter at recommended intervals.	Clogged fuel filter will cause restriction in fuel flow and can cause flow reduction.
DO: Use fuel filters supplied/ recommended fuel filters only.	Spurious fuel filters causes damages to injector, regulator and fuel pump performance.
DO: Ensure that the hoses are routed properly and there are no kinks / rubbing with other components.	Improper routing, kinks and fouling of hoses with other components causes hose damage
DO : Ensure that always sufficient fuel till the strainer height	Avoids Pump running in dry
DO: Replace two O-rings along with replacement/ re-installation of pressure regulator.	For proper functioning of regulator.
DO: Use care during connection of harness to module coupler.	Avoid terminal damage.
DO: Return any dropped, damaged, or suspect material with a tag that describes the problem.	Ensure fast and correct diagnosis of root cause.

3. Diagnostic Tools

3.1. Motor Scanner(for MT05 EMS)

3.1.1. Precautions

- Motor-Scanner is a precision instrument and should be protected from vibration and impact.
- If the unit does not run correctly or the screen is unstable when first turned on, disconnect it from the main lead and try again.
- Make sure the DLC is always firmly inserted into the diagnostic socket.
- Never test electrical signals that exceed the limit of specifications.
- Test cannot be performed by the person who is driving the car.
- This unit should be used and stored in the following conditions:
Ambient temperature: 0~50℃
Relative humidity: <90%

3.1.2. Configurations

Delphi Motor scanner consists of 2 main part: the main units (with diagnostic main cable) and diagnostic connector link (one end is 6PIN connector; the other is the interface for connecting diagnostic main cable). They are shown in figure 34 as below.

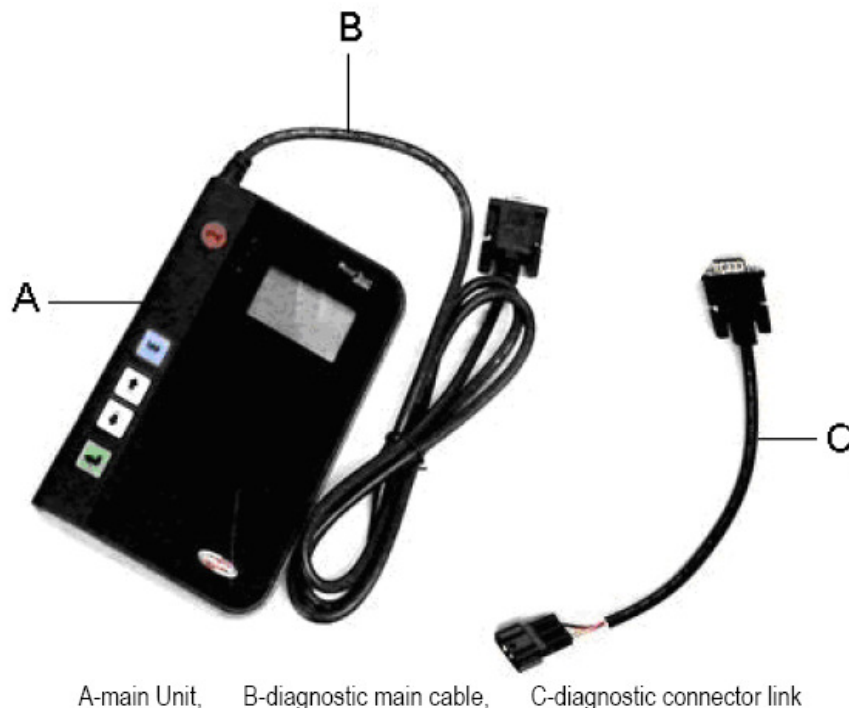
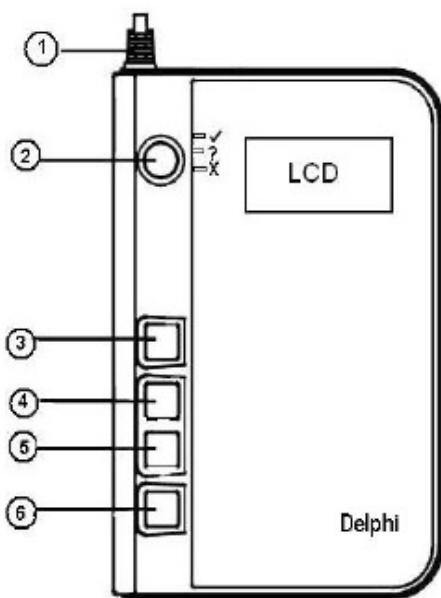

Figure 34

Outline of Main Unit



Main Unit

Figure 35

The 6PIN diagnostic connector link cable and USB type main unit's software update cable are in the delivered package.

1	Diagnostic Cable	To connect the unit and vehicle socket for diagnosis
2	reserved Key	The Key is reserved for future
3	Key	To return to the previous interface.
4	Key	To move the cursor to upper item in the menu
5	Key	To move the cursor to down item in the menu
6	Key	To confirm and execute this operation.

Main Unit Structure

Screen:

128 × 64 array high definition screen with back light for displaying all the information during testing.

Keyboard:

There are 5 keys (one is reserved) on the main unit for selecting and controlling test steps.

3.1.3. Preparations

Connection

- Find the 6PIN diagnostic socket on the motor.
- Connect one end of the diagnostic main cable to the main unit, and the other end to diagnostic socket on the motor, tighten the screws.

Normal Power-on Display

When power is on normally, the unit will display:

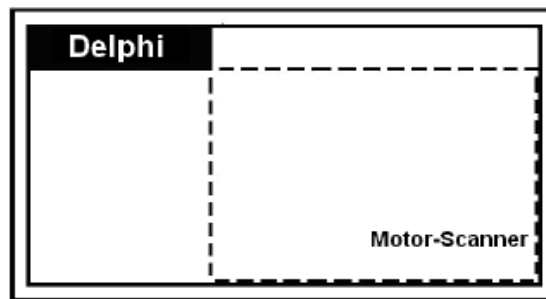

Seconds later, the unit will display:

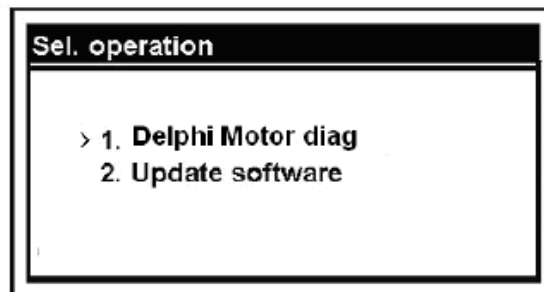

3.1.4. Functions

Delphi Motor-Scanner can be used to diagnose Delphi Engine Management System with functions: Read DTC, Clear DTC, Data Stream, Status Stream, and Record Data.

Operations

When the unit is powered up, the screen will display the interface as below.



Here, we take diagnostic function for demonstration.

Select 1 and press [↵] key, it will display an interface for language selection, as shown below:

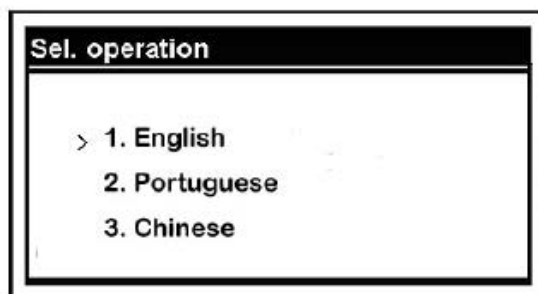

Select 'English' and press [↵] key, it will display information about the diagnostic software version, press [↵] to continue, the interface will display as below:

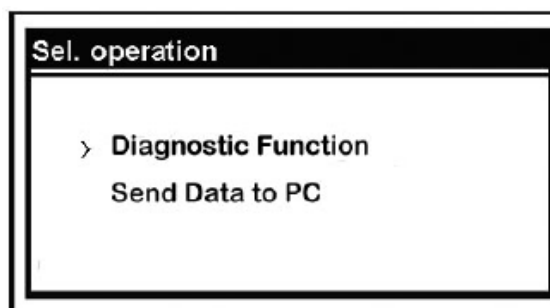

Diagnostic Function

Here, we take 'diagnostic function' for demonstration.

Select 'diagnostic function' and press [↵], the screen will display an interface to indicate 'Delphi-3' diagnostic connector should be used.

Press [↵], the screen will display engine information as below:

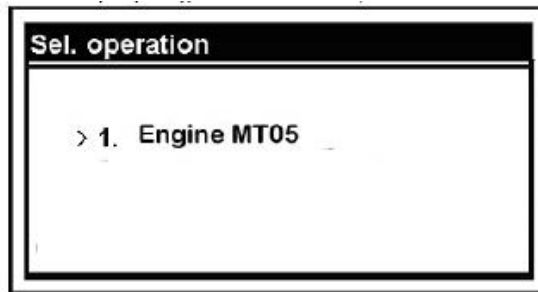

Press [↵], with 'accessing system' fleeting on the screen, then, it will display as below:

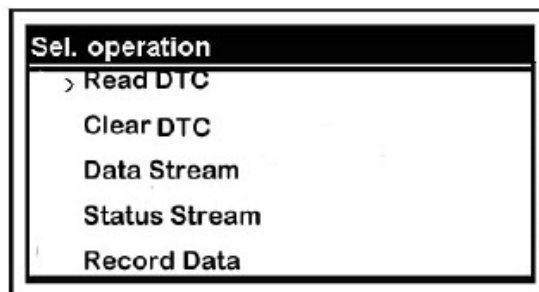

Available functions are as follows:



- Read DTC
- Clear DTC
- Data Stream
- Status Stream
- Record Data

Press [↑] or [↓] key to select function you needed.

1. Read DTC

Select 'Read DTC', and press [↵], it will display fault code as below:

● P0118	P0113	P0122
P0201	P0650	P0135
P0351		

Press [] or [] key to move '.' icon, and select fault code, take 'P0118' for example, it's selected when there is '.' in front of it, press [], the screen will display detailed information of the code, as below:

Temperature of engine	
oil sensor short V	
/ Open	
Code: P0118	01 01

2. Clear DTC

Select 'Clear DTC' and press [], it will display as below:

```
Erase fault memory.  
Trouble code has been  
erased.  
.Press [Esc] key
```

3. Data Stream

Select 'Data Stream' and press [], it will display as below:

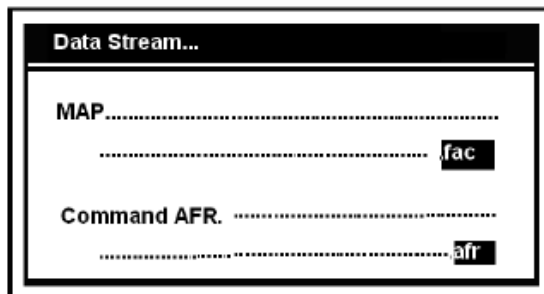

Press [↑] or [↓] key for page up/down to view more. Press [←←] key to exit.

4. Status Stream

Select 'Status Stream' and press [↵], the interface will display as below:

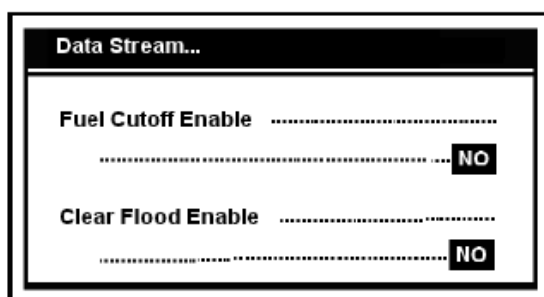





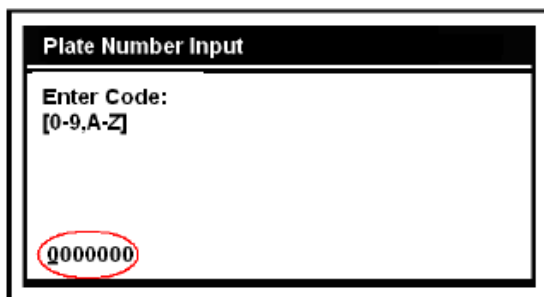

Press [↑] or [↓] key for page up/down to view more. Press [←←] key to exit.

5. Record Data

Select 'Record Data' and press [↵], it will display:



Press [] or [] key to enter code, when the first number of the code was set, press [] to confirm and continue to input the sequent numbers, till all the 7 numbers were input.

When all the 7 numbers were set, press [], the screen will display a message for confirmation of the Plate Number input. Press [] to return to the previous interface to input the code again or press [] to confirm the code.

Press [], another interface will be displayed for you to input date, as below:

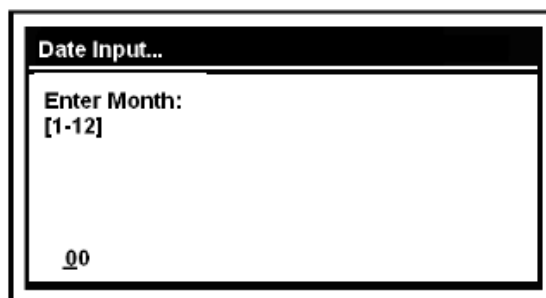

The screenshot shows a rectangular window with a black header bar containing the text "Date Input...". Below the header, the text "Enter Month:" is displayed, followed by "[1-12]" in a smaller font. At the bottom left of the input area, there is a cursor and the number "00".

It's the same way to enter month as vehicle code input.
Month was input, then enter date, as below:

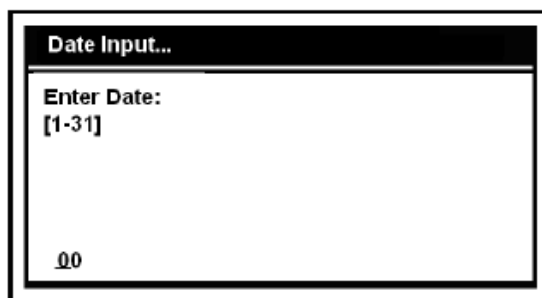

The screenshot shows a rectangular window with a black header bar containing the text "Date Input...". Below the header, the text "Enter Date:" is displayed, followed by "[1-31]" in a smaller font. At the bottom left of the input area, there is a cursor and the number "00".

Then, 'Enter Year' continues, as below:

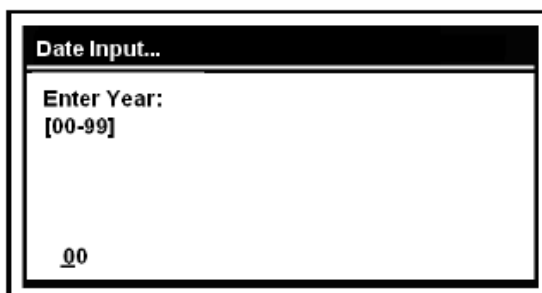

The screenshot shows a rectangular window with a black header bar containing the text "Date Input...". Below the header, the text "Enter Year:" is displayed, followed by "[00-99]" in a smaller font. At the bottom left of the input area, there is a cursor and the number "00".

After that, 'Enter Week' follows, as below:

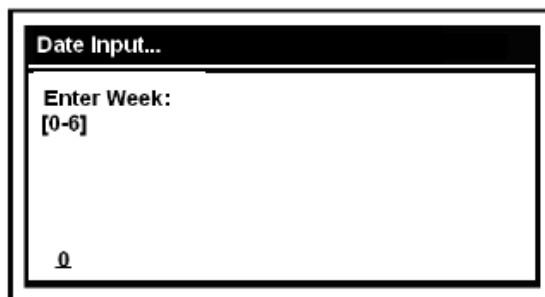

Till now, the 'date input' was completed, and it starts to record data, press [⏪] to stop recording.

3.2. Diag Tool Software(for MC21 EMS)

3.2.1. General Description

DIAG TOOL is software for monitoring the engine status and recording the engine running parameters. It communicates to the ECU via K-Line of the diagnostic connector.

3.2.2. Diagnostic Connector Pin Definition:

The diagnostic connector has 6 pins as shown in figure 36 as below. These pins can be used to perform various diagnostic or service functions. This Diagnostic Tool uses only 3 pins of them, which are +12V battery, Ground and K-line.

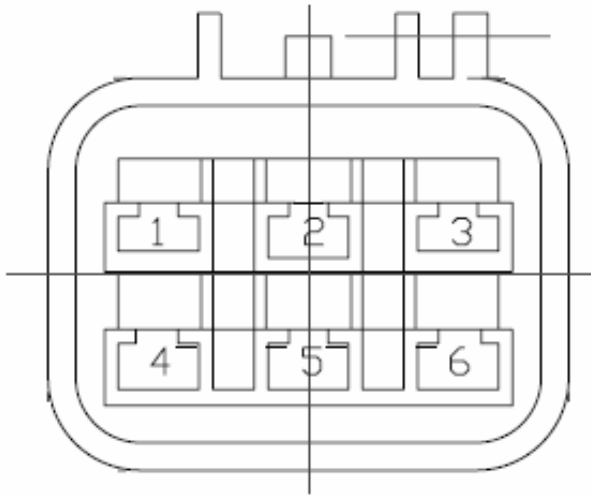

Pin2: Ground
Pin4: K-line
Pin6: +12 V Battery

Figure 36

3.2.3. Diag Tool Software Instruction

Initial setting:

- Use DIAG TOOL cable to connect the computer COM port and the ECM diagnostic connector
- Start DIAG TOOL

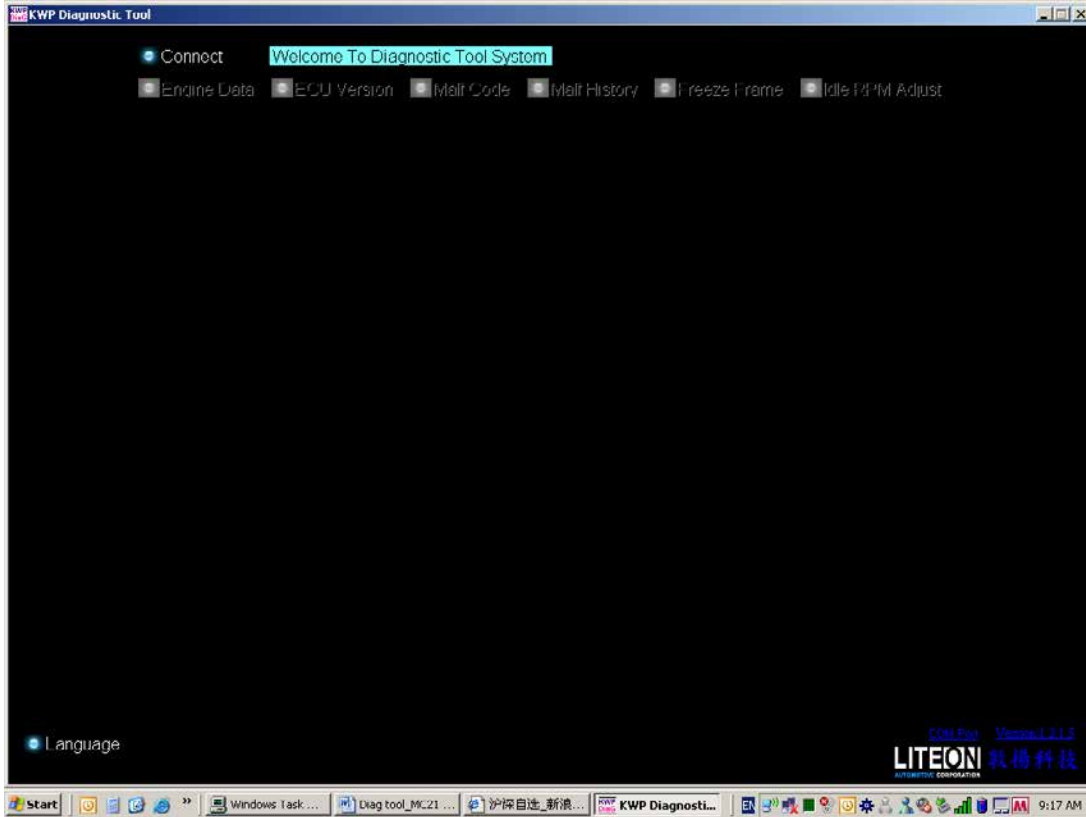

- Click connect to start communication

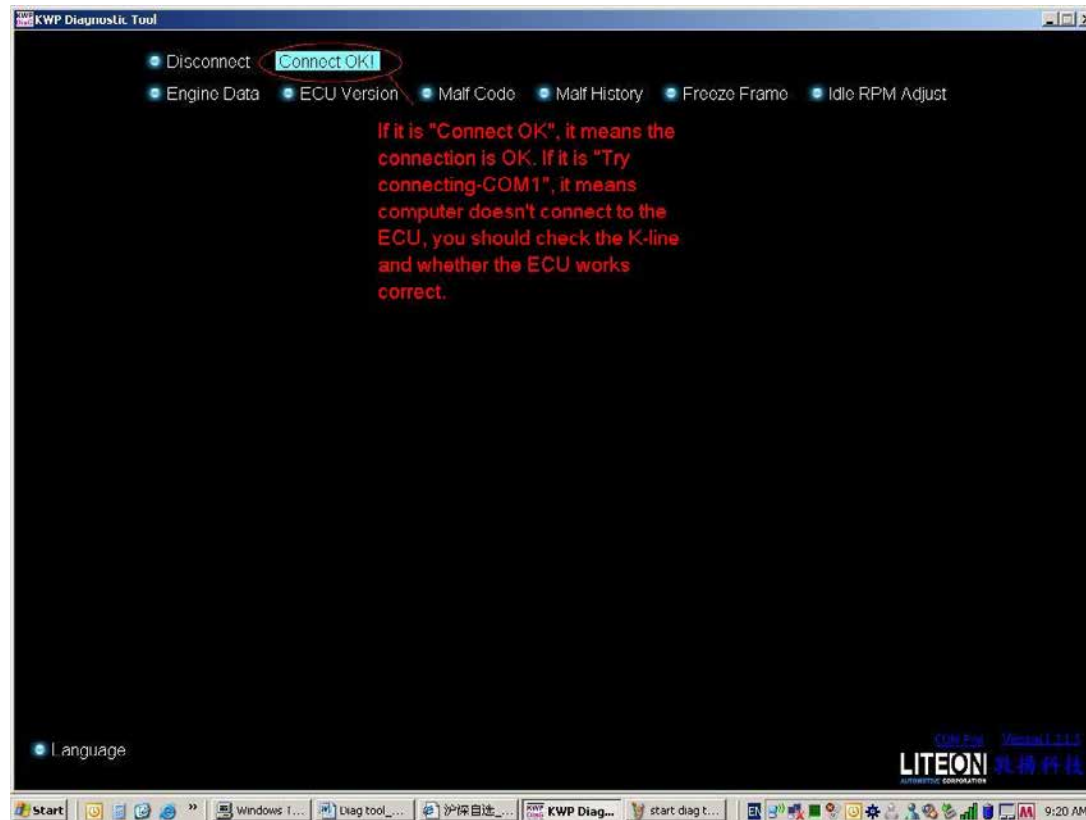

- Click on “Engine Data” to display and monitor the engine parameters.

The screenshot shows the 'KWP Diagnostic Tool' interface with the 'Engine Data' tab selected. The 'Connect' button is highlighted as 'Connect OK!'. Below the navigation bar, a table of engine parameters is displayed. At the bottom, the 'Engine Status' is shown as 'STALL'.

Engine Data					
RPM	0	rpm	Cyl1VESingleFire	219	factor
CLC	128	factor	ColdCyl1VEFactorIdle	0.0	factor
O2Volt	39.22	mV	ColdCyl1VEFactorRun	1.2	factor
IAT_idx	-22	°C	EventIDEnable	Off	flag
Toil_Physical	6	°C	EnableCondMet	Off	flag
VBatt_idx	11.8	V	IdleRPMerr	0	rpm
TPS_idx	84	count	Baro	102	kpa
SA	11	SA	AFRNGKfilt	9.0	AFR
IACCommDuty	0.0	%	Malf8.MIL	On	flag
Cyl1MAP_idx	86.3	kpa	Mode1.NeutralSW	Off	flag
Cyl1AFLCFilteredMAP	0.00	kpa	IACDutyVECcorrect	1.000	factor
Cyl1ExpectMAP	87.16	kpa	MotorStep	0	step
Cyl1EstmatMAPforCorrect	87.16	kpa	MAPCombIDThres	0.00	kpa
Cyl1MAPReadCrankAngle	146	CA	IACAirFlowIntegral	14.8	%
Cyl1AFLCMult	1.00	factor	BLM	128	factor
Cyl1CmndPW	15.787	ms	Fuel1.DFCOEn	Off	flag
Cyl1FinaIVE	187	factor	Fuel1.OSFCOEn	Off	flag
Cyl1VE	208	factor			

Engine Status: **STALL** CRANK IDLE RUN | PEEEn Sequential Cut CLCEn

- Log data
Set the sample rate to typically 0.1 second and specify the data log file and folder.

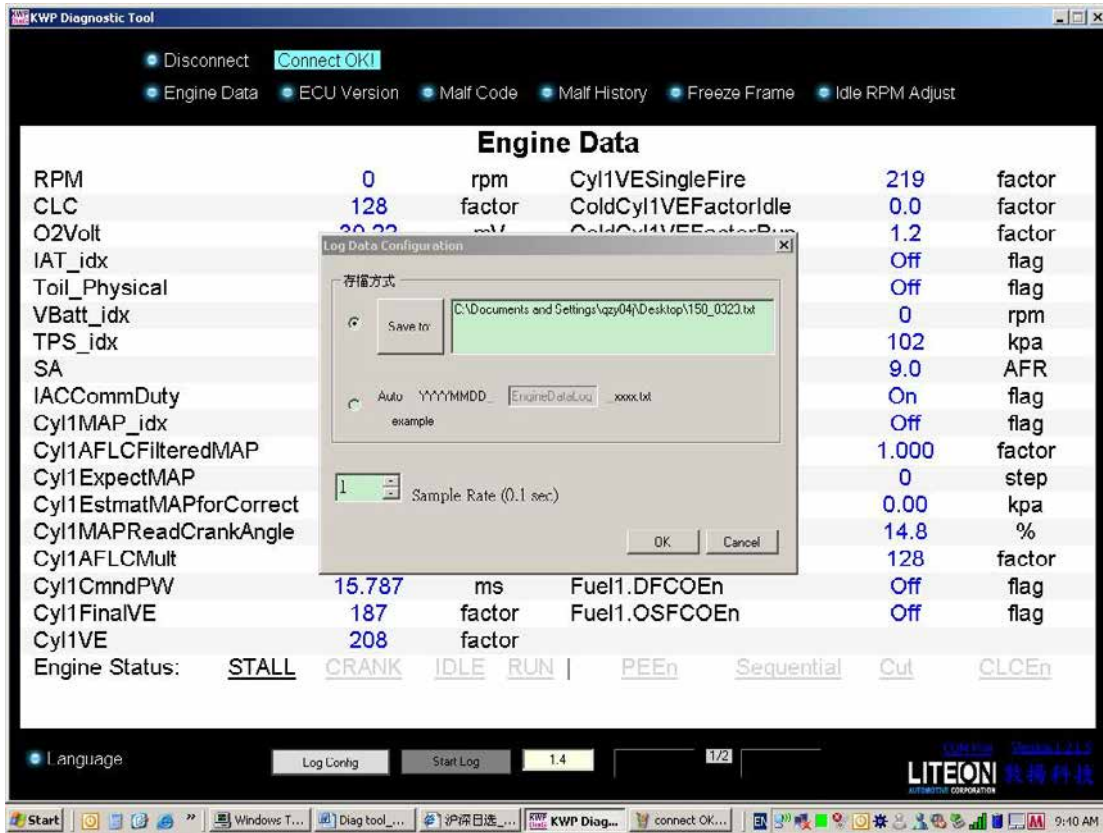

- ECU version



- Click on “Malf Code” to display the current malf codes



- Click on “Malf History” to display the history malf codes

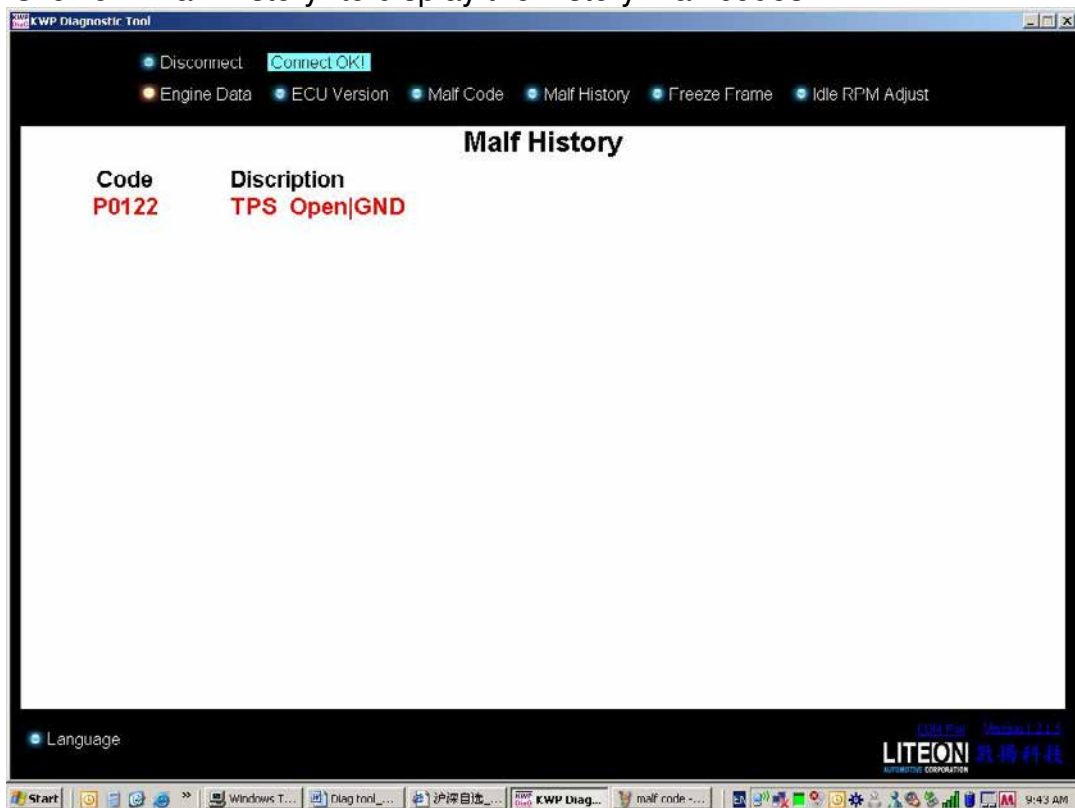

Check the malf code meaning by reading the below table.

MC21 EMS Malf Code			Table:22
故障代码	Description	故障代码描述	闪烁代码
P0106	Map Rationality	进气压力合理性	35
P0107	Map Open/GND	内置进气压力传感器开路或者短接到地	34
P0108	Map Short V	内置进气压力传感器短接到电源	33
P0112	IAT Short GND	进气温度传感器短接到地	69
P0113	IAT Shtort V Open	进气温度传感器短接到电源或者开路	71
P0117	Toil Short GND	发动机温度传感器短接到地	15
P0118	Toil Shtort V Open	发动机温度传感器短接到电源或者开路	14
P0563	Battery voltage high	系统电源电压过高	49
P0122	TPS Open GND	油门位置传感器短接到地或者开路	22
P0123	TPS Short V	油门位置传感器短接到电源	21
P0131	O2 Short GND	氧传感器短接到地	45
P0132	O2 Short V	氧传感器短接到电源	44
P0231	Pump Open/GND	油泵短接到地或者开路	29
P0232	Pump Short V	油泵短接到电源	31
P0601	EEPROM Error	EEPROM 错误	51
P0261	Cylinder 1 Inj Open/GND	一缸喷嘴短接到地或者开路	16
P0262	Cylinder 1Inj Short V	一缸喷嘴短接到电源	17
P1351	Cylinder 1 Ign Short Gnd	一缸点火线圈短接到地	64
P0351	Cylinder 1 Ign Short V	一缸点火线圈短接到电源	42
P1650	MIL Open/GND	故障诊断灯短接到地或者开路	0
P0650	MIL Short V	故障诊断灯短接到电源	0
P1654	TACO Open/GND	发动机转速输出短接到地或者开路	12
P0654	TACO Short V	发动机转速输出短接到电源	11
P0335	Crank Sensor Malfunction	曲轴位置传感器故障	19
P1352	Cyl2 Ign Short GND	二缸点火线圈短接到地	95
P0352	Cyl2 Ign Short V	二缸点火线圈短接到电源	96
P0321	Cyl1 IGBT over current	一缸点火模块电流过大	79
P1321	Cyl2 IGBT over current	二缸点火模块电流过大	23
P0264	Inj_2 Open/GND	二缸喷嘴短接到地或者开路	4
P0265	Inj_2 Short V	二缸喷嘴短接到电源	5

3.3. PCHUD Software(for MT05 EMS)

3.3.1. General Description

PCHUD is software for monitoring the engine status and recording the engine running parameters. It communicates to the ECU via K-Line of the diagnostic connector.

3.3.2. Diagnostic Connector Pin Definition:

The diagnostic connector has 6 pins as shown in figure 37 as below. These pins can be used to perform various diagnostic or service functions. This Diagnostic Tool uses 3 pins, which are +12V battery, Ground and K-line.

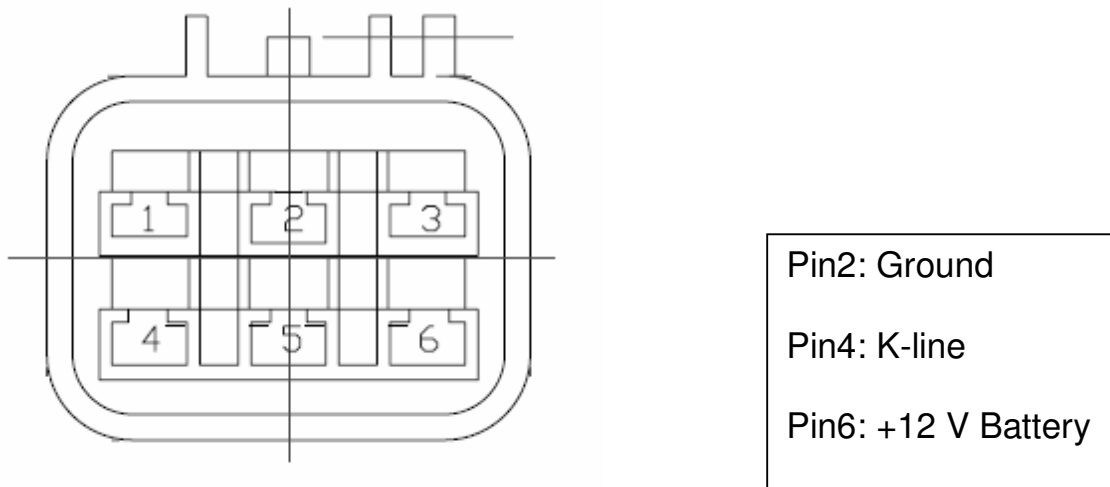

Figure 37

3.3.3. PCHUD Software Instruction

Initial setting:

- Use PCHUD cable to connect the computer COM port and the ECM diagnostic connector
- Start PCHUD

The screenshot shows the Delco PCHUD Application window for engine 10P007EN. The interface includes a menu bar (File, Clear, Gauge, Setup, Playback, Slow, Help), a toolbar with control buttons (STEP REV, PAUSE, FWD, STEP FWD, PLAY BACK, START RECORD, CLR), and a main data display area. The data is organized into columns and rows, showing parameters such as Engine Speed (0 rpm), Throttle Position (0.0 pct), Baro (89.7 kpa), Measured MAP (77.3 kpa), Intake Air Temperature (19.6 degC), and various status bytes. A bottom status bar displays '*** Com Timeout Error ***' and the file path '10P007EN.PAR (Master)'. The Windows taskbar at the bottom shows the system time as 22:04.

- Open the HUD file

This screenshot is identical to the previous one but includes an 'Open HUD File' dialog box. The dialog box is open to the 'c:\pchs_00\1\hud' folder, displaying a list of files including '10P007EN HUD', '10P007EN HUD', '20L1UR60 HUD', 'Chns.hud', 'Chnhd68.hud', 'Chnhdic.hud', and 'Cmsa02.hud'. The 'List files of type' is set to 'HUD File (*.HUD)'. The 'Files of type' dropdown is also set to 'HUD File (*.HUD)'. The background application window remains visible, showing the same engine data and status indicators.

- Open the Par file

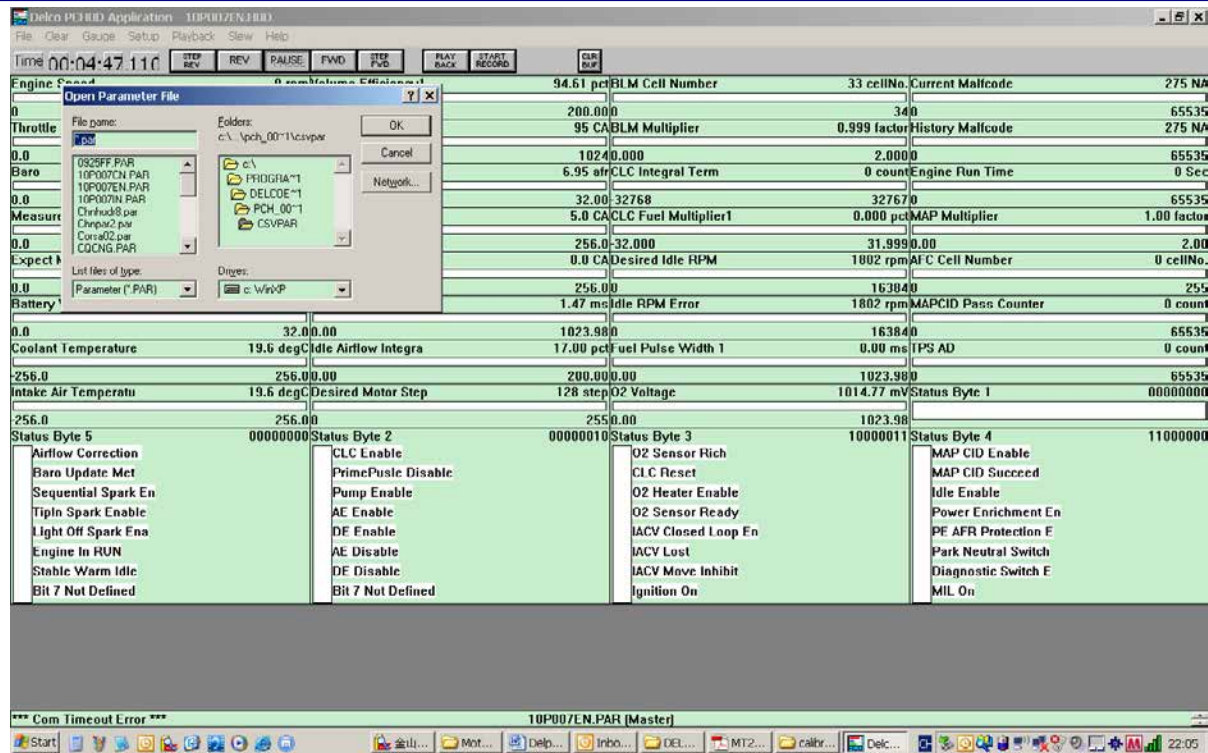

- Set the communication protocol: Keyword 2000

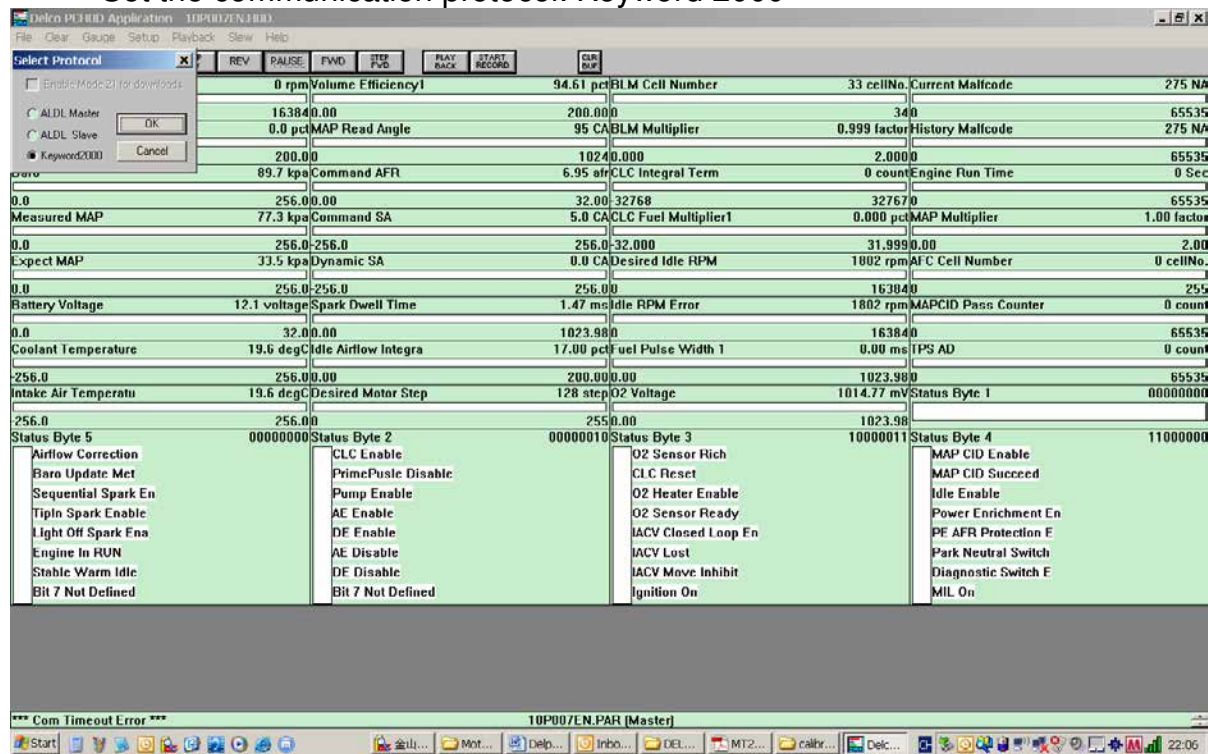

- Set the communication port is COM1 and the baud rate is 10400

The screenshot shows the Delco PCHUD Application interface for engine monitoring. The main window displays a grid of engine parameters with their current values and units. A 'Communications Parameters' dialog box is open on the left, showing baud rate and device ID settings. The status bytes section at the bottom right shows various diagnostic flags.

Parameter	Value	Unit	Parameter	Value	Unit	Parameter	Value	Unit
Volume Efficiency	94.61	pct	BLM Cell Number	33	cellNo.	Current Malcode	275	NA
MAP Read Angle	0.0	pct	BLM Multiplier	0.999	factor	History Malcode	275	NA
Command AFR	16.384	kpa	CLC Integral Term	0	count	Engine Run Time	0	Sec
Command SA	256.0	0.00	CLC Fuel Multiplier1	0.000	pct	MAP Multiplier	1.00	factor
Dynamic SA	256.0	256.0	Desired Idle RPM	1802	rpm	AFC Cell Number	0	cellNo.
Spark Dwell Time	1.47	ms	Idle RPM Error	16384		MAPCID Pass Counter	0	count
Idle Airflow Integra	17.00	pct	Fuel Pulse Width 1	0.00	ms	TPS AD	0	count
Desired Motor Step	128	step	O2 Voltage	1014.77	mV	Status Byte 1	00000000	
Status Byte 2	00000010		Status Byte 3	10000011		Status Byte 4	11000001	

- Monitor the engine running parameters on the computer screen

This screenshot shows the same Delco PCHUD Application interface, but with progress bars added to the parameter rows to indicate their relative values. The status bytes section now includes a legend for each bit, such as 'CLC Enable', 'O2 Sensor Rich', and 'MAP CID Enable'.

Parameter	Value	Unit	Parameter	Value	Unit	Parameter	Value	Unit
Engine Speed	2062	rpm	Volume Efficiency	115.21	pct	BLM Cell Number	24	cellNo.
Throttle Position	10.1	pct	MAP Read Angle	66	CA	BLM Multiplier	0.999	factor
Baro	89.6	kpa	Command AFR	13.22	af	CLC Integral Term	0	count
Measured MAP	89.6	kpa	Command SA	29.1	CA	CLC Fuel Multiplier1	0.000	pct
Expect MAP	35.5	kpa	Dynamic SA	0.0	CA	Desired Idle RPM	1625	rpm
Battery Voltage	12.0	voltage	Spark Dwell Time	1.45	ms	Idle RPM Error	437	rpm
Coolant Temperature	19.6	degC	Idle Airflow Integra	17.00	pct	Fuel Pulse Width 1	7.30	ms
Intake Air Temperature	19.6	degC	Desired Motor Step	138	step	O2 Voltage	1014.77	mV
Status Byte 5	00100000		Status Byte 2	00000110		Status Byte 3	10000111	
0 Airflow Correction			0 CLC Enable			0 O2 Sensor Rich		
1 Baro Update Met			1 PrimePulse Disable			1 CLC Reset		
2 Sequential Spark En			2 Pump Enable			2 O2 Heater Enable		
3 TipIn Spark Enable			3 AE Enable			3 O2 Sensor Ready		
4 Light Off Spark Ena			4 DE Enable			4 IACV Closed Loop En		
5 Engine In RUN			5 AE Disable			5 IACV Lost		
6 Stable Warm Idle			6 DE Disable			6 IACV Move Inhibit		
7 Bit 7 Not Defined			7 Bit 7 Not Defined			7 Ignition On		

- Record data:

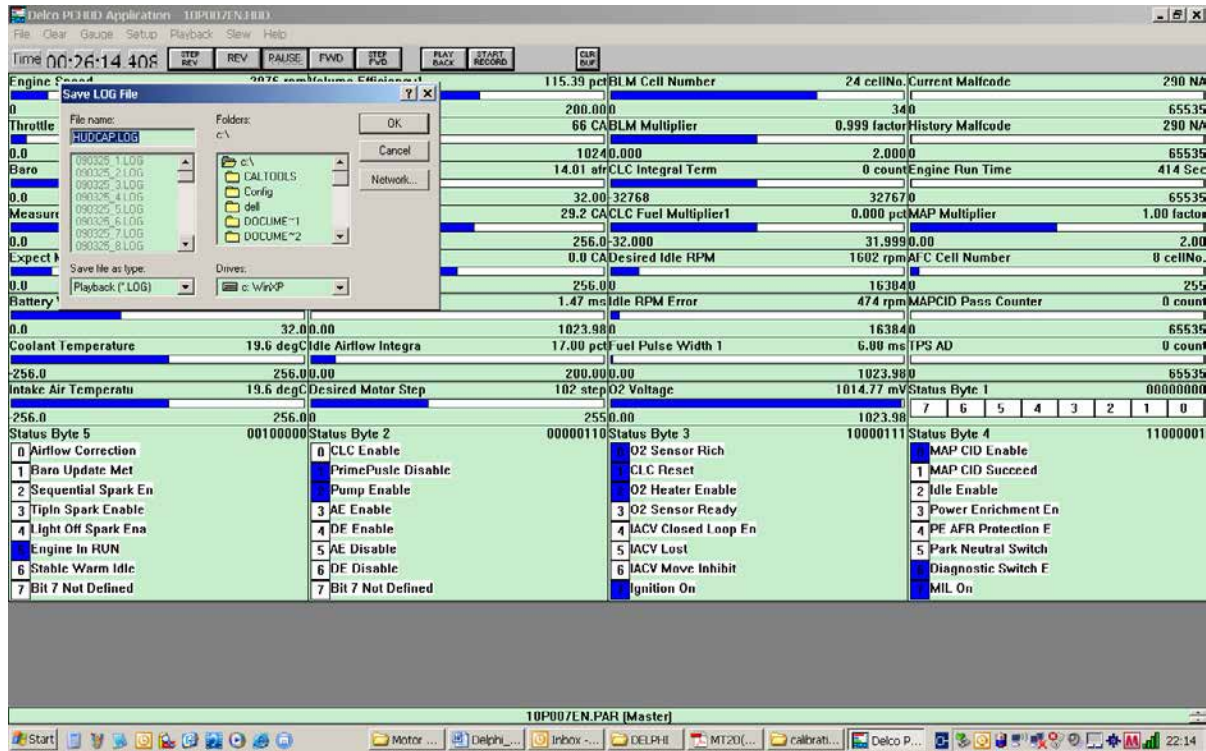

Find the malfunction code:

- Display the current malcode and the history malcode on the screen

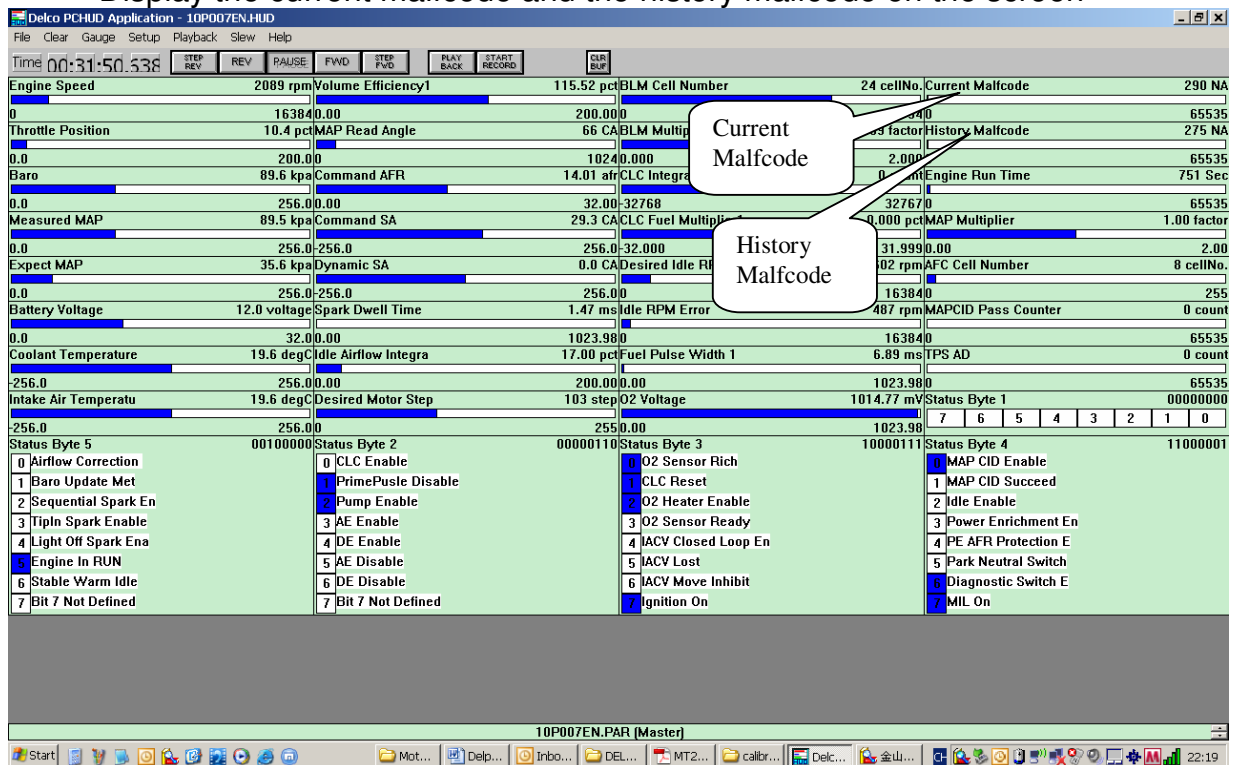

- Check malf code meaning by reading the below table.

Mt05 ECU Malf Code		Table:23
Malf code in MT05	Description	
P0107	MAP Circuit Low Voltage or Open	
P0108	MAP Circuit High Voltage	
P0112	IAT Circuit Low Voltage	
P0113	IAT Circuit High Voltage or Open	
P0117	Coolant/Oil Temperature Sensor Circuit Low Voltage	
P0118	Coolant/Oil Temperature Sensor Circuit High Voltage or Open	
P0122	TPS Circuit Low Voltage or Open	
P0123	TPS Circuit High Voltage	
P0131	O2A Circuit Low Voltage	
P0132	O2A Circuit High Voltage	
P0031	O2A Heater Circuit High Voltage	
P0032	O2A Heater Circuit Low Voltage	
P0201	Injector 1 Circuit Malfunction	
P0202	Injector 2 Circuit Malfunction	
P0230	FPR Coil Circuit Low Voltage or Open	
P0232	FPR Coil Circuit High Voltage	
P0336	CKP Sensor Noisy Signal	
P0337	CKP Sensor No Signal	
P0351	Cylinder 1 Ignition Coil Malfunction	
P0352	Cylinder 2 Ignition Coil Malfunction	
P0505	Idle Speed Control Error	
P0562	System Voltage Low	
P0563	System Voltage High	
P0650	MIL Circuit Malfunction	
P1693	Tachometer Circuit Low Voltage	
P1694	Tachometer Circuit High Voltage	